

# Implementation of Direct Sequence Spread Spectrum Communication System Using FPGA

R.Prabhu<sup>1</sup>, R.Nagarajan<sup>2</sup>, N.Karthick<sup>3</sup>, S.Suresh<sup>4</sup>

<sup>1</sup>Asst. Professor, Department of Electronics and Communication Engineering, Gnanamani College of Technology, Namakkal, India.

<sup>2</sup>Professor, Department of Electrical and Electronics Engineering, Gnanamani College of Technology, Namakkal, India.

<sup>3</sup>Asst. Professor, Department of Electronics and Communication Engineering, Gnanamani College of Technology, Namakkal, India.

<sup>4</sup>Asst. Professor, Department of Electrical and Electronics Engineering, Gnanamani College of Technology, Namakkal, India

**Abstract** — This paper presents the designed and implementation of spread spectrum technology for data transfer to overcome the interference problems associated with narrow band, very high frequency and ultra high frequency data transfer systems. The spread spectrum communication is used to reduce jamming of communication and provides a heightened secure communication. In this paper, the design and analyzes are implemented by Field Programmable Gate Array (FPGA) for baseband spread spectrum communication system using Pseudo Noise Sequences (PNS) for spreading digital data. The sequence generator and direct sequence spread spectrum (DSSS) for a single user is implemented in a FPGA module. The generated pseudo noise sequences are investigated for autocorrelation, cross correlation and balance properties. The bit error rates performance of the system is evaluated in multiuser environment under AWGN and reveals that, the DSSS system using pseudo noise sequences as spreading sequences significantly outperforms for the conventional PN sequences system

**Keywords**— Bit Error Rates (BER), Field Programmable Gate Array (FPGA), Direct Sequence Spread Spectrum (DSSS), Pseudo Noise (PN) and Spread Spectrum (SS).

## I. INTRODUCTION

The spread spectrum (SS) has been defined as a means of transmission in which the signal occupies bandwidth much in excess of the minimum necessary to send the information, the band spread is accomplished by utilizing a code which is independent of the data and a synchronized reception with the code at the receiver is used for de-spreading and subsequent data recovery. The SS communications are mostly used today for military, industrial, avionics, scientific and civil. The merits of using SS include the low power spectral density. As the signal is spread over a large frequency band, the power spectral density is getting very low, so other communications systems do not suffer from this kind of communications. However the Gaussian Noise level is increasing [1].

The ability to utilize the satellite pay load channels, which is achievable as the transmitted signal is spread in such a way that it become noise like and thus would not interfere with the pay load traffic and interference limited operation. The security due to unknown random codes, as the applied codes is in principle unknown to a hostile user. This means that it is not easy to possible to detect the message of another user. Applying spread spectrum implies the reduction of multi path effects and random access possibilities. As users can start their transmission at any arbitrary time and better anti-jam performance. The cost paid is the need of a larger bandwidth which already present due to the usage of the existing communication channels and the need for good synchronization at the receiver to detect the reception of the signal [2].

The spread spectrum techniques for digital communication were originally developed for military applications because of their high security and their susceptibility to interference from other interceptors. Now a day spread spectrum techniques are being used in variety of commercial applications such as mobile and wireless communication [3]. In order to spread the bandwidth of the transmitting signals, the binary pseudo noise (PN) sequences have been used extensively in spread spectrum communication systems. One of the most commonly used PN sequences in direct sequence spread spectrum (DSSS) is maximal length sequences (m-sequences) [4]. The length of m-sequences depends on the number of shift registers used in the circuit. The good correlation properties can be achieved with m-sequences. The ability to predict future sequence is nevertheless possible though difficult; therefore transmission is not completely secured [5]. The number of sequences generated by linear feedback shift registers (LFSR) may be insufficient for wideband DSSS with a very large number of users. In addition, LFSR techniques provide limited flexibility in incorporating security into multiple user systems [6].

The use of chaotic sequences as spreading sequences has been proposed in the literature because of its sensitivity to

initial conditions and has characteristics similar to random noise. However reliable electronic hardware implementations of chaos based PN sequence generators based on recursion of maps realized by piecewise linear analogue functions and output quantization have not been possible due to manufacturing process variations among different integrated circuit production lots, transistor mismatches and electronic noise [7]. The pseudo-chaotic sequence generator modified version is presented in this paper. The non linear feedback shift registers (NLFSR), have shown that chaotic spreading sequence can be used as an inexpensive alternative to the LFSR sequences such as m-sequences and gold sequences.

## II. SPREAD SPECTRUM

The electromagnetic spectrum refers to the full range of all frequencies of electromagnetic radiation and also to the characteristic distribution of electromagnetic radiation emitted or absorbed by that particular object. The devices used to measure an electromagnetic spectrum are called spectrograph or spectrometer. The visible spectrum is the part of the electromagnetic spectrum that can be seen by the human eye. The wavelength of visible light ranges from 390 to 700 nm. The absorption spectrum of a chemical element or chemical compound is the spectrum of frequencies or wave lengths of incident radiation. The emission spectrum refers to the spectrum of radiation emitted due to an atom or molecule making a transition from a higher to a lower energy state. The light from many different sources contains various colors, each with its own brightness or intensity. A rainbow, or prism, sends these component colors in different directions, making them individually visible at different angles [8].

The graph of the intensity plotted against the frequency showing the brightness of each color is the frequency spectrum of the light. When all the visible frequencies are present equally, the perceived color of the light is white, and the spectrum is a flat line. Therefore, the flat line spectrums in general are often referred to as white, whether they represent light or another type of wave phenomenon (sound, for example, or vibration in a structure). In radio and telecommunications, the frequency spectrum can be shared among many different broadcasters [9].

The radio spectrum is the part of the electromagnetic spectrum corresponding to frequencies lower below 300 GHz, which corresponds to wavelengths longer than about 1 mm. The microwave spectrum corresponds to frequencies between 300 MHz to 300 GHz, wavelength between the distances of one meter to one millimeter. Each broadcast radio and TV station transmits a wave on an assigned frequency range, called a channel. When many broadcasters are present, the radio spectrum consists of the sum of all the individual channels, each carrying separate

information and spread across a wide frequency spectrum. Any particular radio receiver will detect a single function of amplitude (voltage) vs. time [10]. The radio then uses a tuned circuit or tuner to select a single channel or frequency band and demodulate or decode the information from that broadcaster. If made a graph of the strength of each channel vs. the frequency of the tuner, it would be the frequency spectrum of the antenna signal [8].

The different SS techniques are available, but all have one idea in common: the key (also called code or sequence) attached to the communication channel. The manner of inserting this code defines precisely the SS technique in question. The term spread spectrum refers to the expansion of signal bandwidth, by several orders of magnitude in some cases, which occurs when a key is attached to the communication channel. The formal definition of SS is more precise: spread spectrum is an RF communications system in which the baseband signal bandwidth is intentionally spread over a larger bandwidth by injecting a higher frequency signal [11], [12].

As a direct consequence, energy used in transmitting the signal is spread over a wider bandwidth and appears as noise. The ratio (in dB) between the spread baseband and the original signal is called processing gain. The typical SS processing gains run from 10dB to 60dB. To apply an SS technique, simply inject the corresponding SS code somewhere in the transmitting chain before the antenna, that injection is called the spreading operation. The effect is to diffuse the information in a larger bandwidth. Conversely, can remove the SS code (dispersing operation) at a point in the receive chain before data retrieval. The effect of a dispersing operation is to reconstitute the information in its original bandwidth. Obviously, the same code must be known in advance at both ends of the transmission channel [13]. The spread spectrum operation diagram is shown in Figure 1.

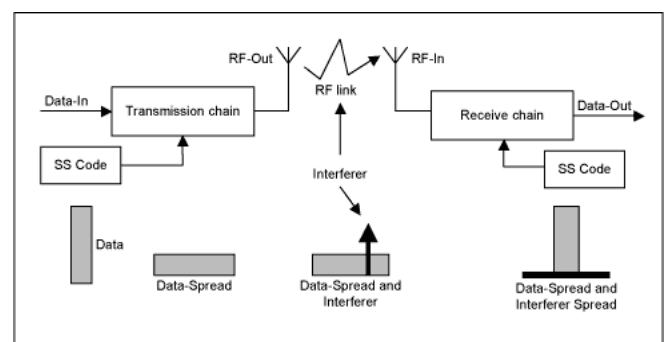

Fig.1: Spread Spectrum

The quadrature phase shift keying (QPSK) uses four points on the constellation, equispaced around a circle with four phases; QPSK can encode two bits per symbol, with gray coding to minimize the BER sometimes misperceived as

twice the BER of binary phase shift keying (BPSK). The mathematical analysis shows that QPSK can be used either to double the data rate compared with a BPSK system while maintaining the same bandwidth of the signal, or to maintain the data rate of the BPSK but halving the bandwidth needed. In this latter case, the BER of QPSK is exactly the same as the BER of BPSK and deciding differently is a common confusion when considering or describing QPSK. The transmitted carrier can undergo numbers of phase changes [14].

The given radio communication channels are allocated by agencies such as Federal Communication Commission giving a prescribed (maximum) bandwidth, the advantage of QPSK over BPSK becomes evident: the QPSK transmits twice the data rate in a given bandwidth compared to BPSK - at the same BER. The engineering penalty that is paid is that QPSK transmitters and receivers are more complicated than the ones for BPSK. However, with modern electronics technology, the penalty in cost is very moderate [15].

As with BPSK, there are phase ambiguity problems at the receiving end, and differentially encoded QPSK is often used in practice. The implementation of QPSK is more general than that of BPSK and also indicates the implementation of higher order PSK. Writing the symbols in the constellation diagram in terms of the sine and cosine waves used to transmit them:

$$s_n(t) = \sqrt{\frac{2E_s}{T_s}} \cos\left(2\pi f_c t + (2n - 1)\frac{\pi}{4}\right), \quad n = 1, 2, 3, 4.$$

This yields the four phase's  $\pi/4, 3\pi/4, 5\pi/4$  and  $7\pi/4$  as needed. This results in a two-dimensional signal space with unit basis functions

$$\phi_1(t) = \sqrt{\frac{2}{T_s}} \cos(2\pi f_c t)$$

$$\phi_2(t) = \sqrt{\frac{2}{T_s}} \sin(2\pi f_c t)$$

$$\left( \pm\sqrt{E_s/2}, \pm\sqrt{E_s/2} \right).$$

The first basis function is used as the in-phase component of the signal and the second as the quadrature component of the signal. Hence, the signal constellation consists of the signal-space 4 points. The factors of 1/2 indicate that the total power is split equally between the two carriers. Comparing these basis functions with that for BPSK show clearly how QPSK can be viewed as two independent BPSK signals [3].

**III. DIRECT SEQUENCE SPREAD SPECTRUM**

The Pseudo Noise (PN) is defined as a coded sequence of 1's and 0's with certain auto correlation properties. The

system of sequences used in spread spectrum communication is usually periodic in that a sequence of 1's and 0's repeats itself exactly with a known period. The m-sequence represents a commonly used periodic PN sequence. Such sequences are long periods and require simple instrumentation in the form of a LFSR. Indeed, they possess the longest possible period for this method of generation [16]. The generated m-sequence is always periodic with a period of  $N=2^m-1$  where m indicates is the length of the shift register. The Figure 2 shows the block diagram of PN Sequence Generator.

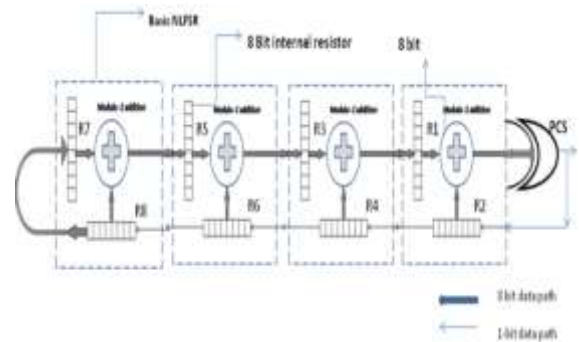

**Figure 2** Block Diagram of PN Sequence Generator

There are many types of spread spectrum techniques as: Direct sequence, frequency hopping, time hopping and hybrid system. The direct sequence contrasts with the other spread spectrum process, in which a broad slice of the bandwidth spectrum is divided into many possible broadcast frequencies. In general, frequency hopping devices use less power and are cheaper, but the performance of DS-CDMA systems is usually more reliable. Thus, in this paper deal only with direct sequence spread spectrum method. In direct sequence spread spectrum the base-band waveform is XOR by the PNS sequence in order to spread the signal. After spreading, the signal is modulated and transmitted [17], [18].

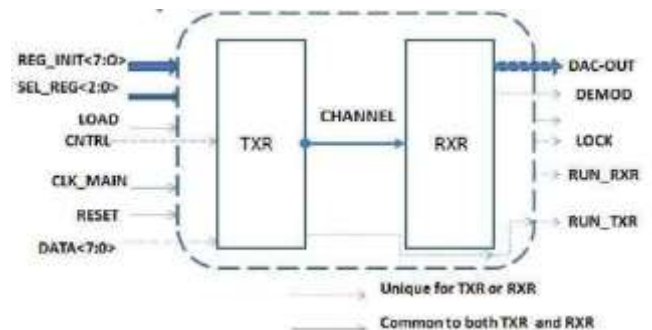

**Fig.3:** Block Diagram of DSSS

The Figure 3 shows the block diagram of DSSS. The bandwidth expansion factor also called the processing gain (K), can be defined as the ratio between the transmitted

spread spectrum signal bandwidth (B) and the bandwidth of the original data sequence (B message) where the processing gain is nearly the ratio of the spread bandwidth to the information rate R (bits/s) and it is much greater than unity. The spread spectrum transmitter use similar transmits power levels to narrow band transmitters. Because spread spectrum signals are so wide, they transmit at a much lower spectral power density, than narrow band transmitters. The spread and narrow band signals can occupy the same band, with little or no interference. The interference rejection capability arises from low mutual correlation between the desired signal and the interfering signal ensured by the codes [19], [20].

This capability is the main reason for all the interest in spread spectrum today. The given equation represents the DSSS signal.

$$S_{ss} = \sqrt{2 E_s/T_s} [m(t) \otimes p(t)] \cos(2 \pi f_c t + \theta)$$

Where:

m(t) is the data sequence,

T<sub>s</sub> is duration of data symbol.

p(t) is the PCS spreading sequence,

f<sub>c</sub> is the carrier frequency,

θ is the carrier phase angle at t=0

The spread spectrum having the following advantages such as: jamming resistance for intended or unintended jamming. A single channel is shared among multiple users. Interception is hampered due to reduced signal/background noise level. The relative timing between transmitter and receiver is determined. In DSSS a sine wave is pseudo randomly phase modulated with a continuous string of pseudo noise code symbols called "chips", each of these chips has a much shorter duration than an information bit. In effect information signal is modulated by chips sequence which is much faster. Therefore, the chip rate is much higher than information signal bit rate. In DSSS the chip sequences produced by the transmitter to modulate the signal is known at receiver end and receiver uses the same chip sequences to demodulate [21], [22].

#### IV. FPGA IMPLEMENTATION OF DSSS SYSTEM

In this paper, the conventional PN sequence system is replaced by PCS (pseudo-chaotic sequence) for a DSSS system. The block diagram of the implemented DSSS system with transmitter and receiver, and inter connection between them is shown in Figure 3. In this Figure 3 shows that channel is the only connection between transmitter and receiver; assuming clock has been synchronized and channel is ideal. In this DSSS system, we spread the data bits using PCS sequence which are generated by using PCS generator. To generate PCS sequence, need to initialize the 8 bit registers R1 to R8 of PCS generator. To load eight registers of the PCS generator to set load=1 and the

corresponding registers R1 to R8 are selected. The 8 bit initial values to each of these 8 registers are loaded using 8 pin of the register unit [23].

After loading the initial values to all the 8 registers, ready out pin gives a signal to the user. At the same time a signal ready is set to high which gives an indication to the control circuit that it can start its operation. Initially before loading the initial values to the registers R1 to R8, the control circuit signals busy and done are not enabled i.e., busy =1 and done=0. As soon as ready=1, then the signal busy=0. The tracking and synchronization of the receiver can be done easily by sending first 8 bit data as "11111111". In that condition, the message source sends a signal in the form of reload signal to the control circuit to indicate that it is ready to send the data. Once this happens the 8 bit data is sent parallel and stored in a buffer register of control circuit in the next clock cycle [24].

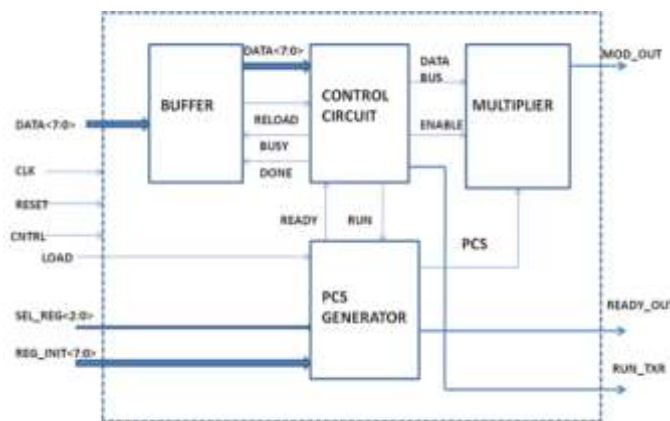

Fig.4: Block Diagram of Transmitter

After receiving the 8 bit data frame, the control circuit enables the PCS generator by setting the signal run=1, also enables the multiplier by setting enable=1 and indicates the buffer that it is busy by setting the signal busy=1. During this time the PCS generator starts generating the 32-bits of PCS sequence. The control circuit then transfers one bit at a time serially to the multiplier where it is multiplied by the 32-bits of generated PCS sequence resulting in a 32-bits of spread sequence and the same is transmitted. After the first data bit is spread by 32-bits of PCS sequence, the second data bit is received in the multiplier and is multiplied by the next 32-bits of the PCS sequence. Hence the PCS generator generates a total of 256 bits to spread all the 8-bits of data. After transmitting all the 256 bits with respect to one frame of data i.e., 8-bits of data, the control circuit makes signal done=1 and busy=0. At that time the control circuit is ready to accept next frame of 8-bits of data. In this way the operation of the transmitter repeats and maintains the gap between the two frames. The Figure 4 shows the block diagram of transmitter [25].

The internal block diagram of the receiver is shown in Figure 5. It consists of detector, control circuit, PCS generator and demodulator. The receiver mainly works in 3 phases: the training phase, the detection phase, and the dispreading phase. Before the training phase, the 8 bit registers R1 to R8 are again initialized with the same initial values used in the transmitter. This is indicated by setting ready =1 by the PCS generator to the control circuit. During the training phase the control circuit keeps the signal ld=1 and enable=0 and run=1. Now the detector is initialized with a training sequence i.e., the first 256 bits of the PCS sequence are loaded into the 8 lower registers, each with 32-bits of the detector. In the detection phase, the control circuit resets ld=0 and run=0. During this phase the received data of 256 bits are loaded into the upper 8 registers of detector, each register with 32-bits and is compared with the bit pattern which is already stored in the lower 8 registers of the detector [26].

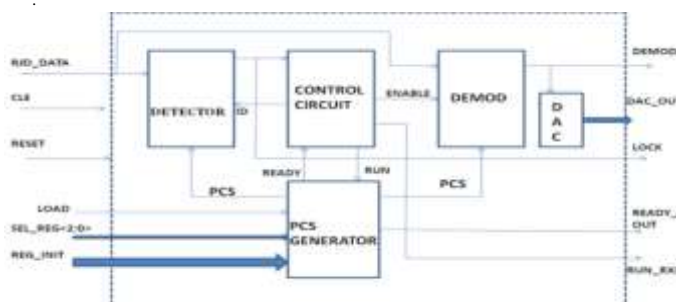

Fig.5: Block Diagram of Receiver

The spread spectrum technology is a new type of data transfer designed to overcome the interference problems associated with narrow-band very high frequency and ultrahigh frequency data transfer systems. The spread spectrum communication is used to reduce jamming of communication and provides a heightened secure communication. In this paper we specifies the design and Field Programmable Gate Array (FPGA) implementation of a baseband spread spectrum communication system using Pseudo-Noise Sequences (PNS) for spreading digital data.

In this paper there are eight bit input message signal are used. The splitter block in the circuit split the message signal for two bits for each clock cycle to produce two message signals. Hear the splitter block using multiplexer logic function. The splitter flow control splits a message into separate fragments, and then sends these fragments one at a time to the next message processor in the flow. The segments are identified based on an expression parameter, usually written in Mule expression language (MEL), but other formats can be employed also. The collection aggregator flow control is used to reassemble the parts of the original message. the re-sequencer flow control to put

the parts back into the original sequence in case they are shuffled out of order. The splitting and aggregating the message is especially useful when you intend to process the split parts in asynchronous flows running on separate servers. Together, the splitter and aggregator flow controls allow sharing the workload among several servers and still being able to reassemble the message after its process.

In this address generator block was generate the two bit address for each cycle in this address generator using for counter logic function .first the counter initial position is '0' when we give enable signal means that time will start for count that was generate for continues two bit address for each clock. The control unit was control the input message signal .the control unit was controlled by the carrier wave generator. The DSSS technique was basically using for four types of carrier signal there are, Sine wave, Inv-sine wave, Cos wave and Inv-cos wave. The carrier wave fully generated after that give one enable signal for each carrier signal any one signal was reach to the control unit means the control unit was using for XOR logic function [27].

The definition of proper sampling is quite simple. Suppose the sample is a continuous signal in some manner. If you can exactly reconstruct the analog signal from the samples, you must have done the sampling properly, even if the sampled data appears confusing or incomplete. In the analog signal is a constant DC value, a cosine wave of zero frequency. Since the analog signal is a series of straight lines between each of the samples, all of the information needed to reconstruct the analog signal is contained in the digital data. According to our definition, this is proper sampling, the sine wave frequency of 0.09 of the sampling rate. This might represent, for example, a 90 cycle/second, the sine wave being sampled at 1000 samples/second. Expressed in another way, there are 11.1 samples taken over each complete cycle of the sinusoid wave. These samples correspond to only one analog signal, and therefore the analog signal can be exactly reconstructed, again, an instance of proper sampling. The situation is made more difficult by increasing the sine wave's frequency to 0.31 of the sampling rate [28].

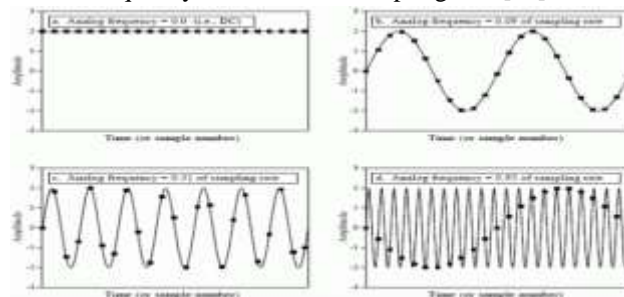

Fig.6: Carrier Wave Generators

The Figure 6 shows the Carrier Wave Generators. The sampling theorem indicates that a continuous signal can be properly sampled, only if it does not contain frequency components above one-half of the sampling rate. For instance, a sampling rate of 2,000samples/second requires the analog signal to be composed of frequencies below 1000 cycles/second. If frequencies above this limit are present in the signal, they will be aliased to frequencies between 0 and 1000 cycles/second, combining with whatever information that was legitimately there.

$$y(t) = A \sin(2\pi ft + \varphi) = A \sin(\omega t + \varphi)$$

Where:

A= Amplitude of the deviation function from zero.

f = Frequency of oscillations (cycles) that occur each second

$\omega = 2\pi f$ , the angular frequency, the rate of change of the function argument in units of radians per second

$\varphi$  = phase, specifies (in radians) where in its cycle the oscillation is at  $t=0$ .

In electronics, a multiplexer (or mux) is a device that selects one of several analog or digital input signals and forwards the selected input into a single line. A multiplexer of  $2^n$  inputs has n select lines, which are used to select which input line to send to the output. Multiplexers are mainly used to increase the amount of data that can be sent over the network within a certain amount of time and bandwidth. A multiplexer is also called a data selector. Multiplexers can also be used to implement Boolean functions of multiple variables. An electronic multiplexer makes it possible for several signals to share one device or resource, for example one or one communication line, instead of having one device per input signal. Conversely, a demultiplexer (or demux) is a device taking a single input signal and selecting one of many data-output-lines, which is connected to the single input. A multiplexer is often used with a complementary demultiplexer on the receiving end. An electronic multiplexer can be considered as a multiple-input, single-output switch, and a demultiplexer as a single-input, multiple-output switch [29].

The binary information that is stored within such a device is specified in some fashion and then embedded within the hardware in a process is referred to as programming the device. The word "programming" here refers to a hardware procedure which specifies the bits that are inserted into the hardware configuration of the device. ROM is one example of a PLD. Other such units are the Programmable Logic Array (PLA), Programmable Array Logic (PAL), and the Field-Programmable Gate Array (FPGA). A PLD is an integrated circuit with internal logic gates connected through electronic circuits [30].

In our project we go for store the incoming carrier wave to demodulate process. Why we go for ROM here we are already store the signal value according to transmission of the carrier signal for avoid the transmission cycle only. here our project we store the 256byte of sample values of our carrier signal .here we can decide which set of signal first go to the correlator block. The signal is taken out as per the carrier transmission. The ROM is constructed in two dimension array. The width is 8 bit and depth is 256 byte. Here we store the 256 byte of samples which is transmitted in the transmitter side. The function is when we receive the signal it will stored in ROM. After that every clock when reset is disabling it will send 64 bit of data as a output. The ROM hold 256 byte of sample values so it has 2048 bit values.it will send 64 bit per clock cycle. Then the output is goes to the correlator block.

The device used is known as correlator or detector. In this project, we have used a modified version of conventional detector at the receiver to detect the signal from the transmitter and to achieve synchronization between the transmitter and receiver during the communication in DSSS system that uses PN sequence. The detection of signal from the intended transmitter at receiver and to achieve the synchronization between them is very important in DSSS system specifically when the system uses pseudo noise sequence. The correlator is constructed by multiplier with adder. When the input signal is received from ROM it will split in to 8 bits. It will receive 64 byte of data and split the 64 byte of data and multiply with carrier signal samples to every byte data. Finally using adder we will add all the results. So we get 16 bit as a output.

The comparator is used to compare the output value of correlator block. it compare the four set carrier signals and given to a two bit of output .it will receive a 14 bit of input the comparator has already known four set constant value, so that the comparator compare the input value with the constant output, from that it will send a 2 bit of output, the out is goes to the shifter block. The shifter is a sequential circuit; it is constructed by flip-flops or registers. In this circuit using 8 bit left shift registers for design. The shift registers is used to shift the input data and store the all 8 bit data. It will send the output when the 8 bits are received from the comparator. When the reset is disable it will receive the first two bit of input and shift two positions to the left at the second clock, it will receive another two bit of input and shift two bit to the left side. Then it will receive another two bit. The same process repeats at the fourth clock it will receive the last two bits of value it will shift again two bit and to the output of 8 bits. In our design shift registers is used in asynchronous clock.

Here we generate the same PN sequence already generated in the transmitter nodule. The PN sequence generator has

the seed bit, which is act as our security key. Without PN sequence we cannot encrypt our original message signal. In general, the PN sequence generated by a polynomial equation. The LFSR (linear feedback shift register) is used to generate the PN sequence but here using a XOR gate only for generating PN sequence in the data flow model. In this design the PN generator with only using XOR gates. It is one of the basic gates. The output is high when the both inputs are not equal. The output is zero if the inputs are same. Here XOR gate is used to mix the input signal with the pseudo noise signal. The XOR gate receive the two inputs one from the shifter block another one from the PN sequence generator, shifter block output is 8 bit. PN sequence output is 8 bit it will XOR the both the inputs then it will give the output as 8 bit; this is what our original message signal. Finally we get our original message signal. The XOR gate gives the original message signal. Here the PN sequence seed bit is keep it as confidential. So finally get the original message signal using of direct sequence spread spectrum.

### V. SIMULATION RESULTS

Figure 7(a), (b), (c), (d) and (e) show the simulation results of the direct sequence spread spectrum, Carrier signal, transmitter final waveform, ROM waveform, correlator waveform and receiver waveform.

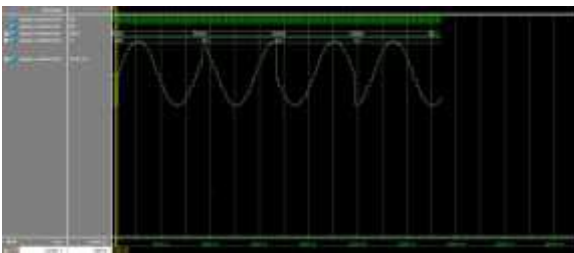

Fig. 7(a): Carrier Signal

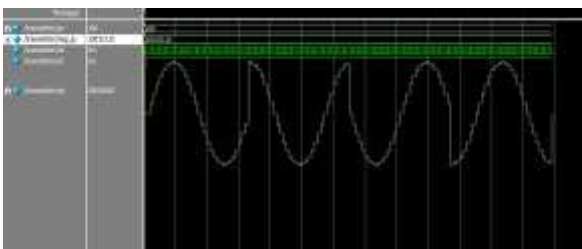

Fig. 7(b): Transmitter Final Waveform

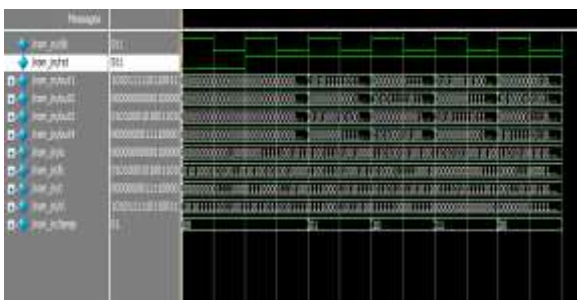

Fig. 7(c): ROM Waveform

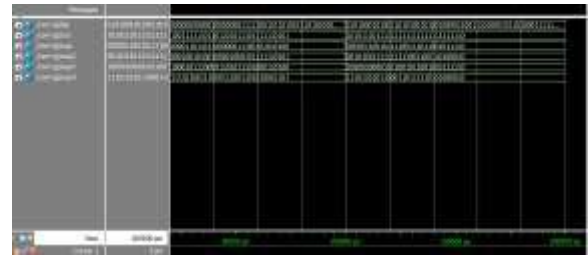

Fig. 7(d): Correlator Waveform

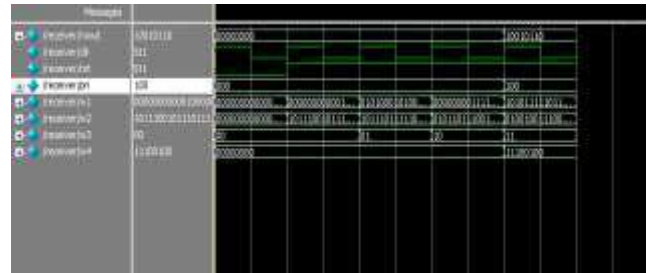

Fig. 7(e): Receiver Waveform

### VI. CONCLUSION

In this paper, The PCS generator is discussed based on the model. The initial conditions of the PCS sequence generators can be randomly selected to produce pseudo-chaotic sequence with good correlation properties upon exhaustive comparison to be distinct sequences rather than phases of the same sequence. The family of pseudo chaotic PN sequences proved good correlation properties than conventional m-sequences and hence it can be useful for DSSS. The Pseudo chaotic sequence generation with its robust digital implementation is to avoid many difficulties associated with analog chaotic circuits. The large set of system parameters (initial conditions and internal configuration of cells and generators) and the non linear nature of the feedback generation circuitry lead to potential applications for programmable secure communication systems. The tests will have shown that simply using random selections of initial conditions can provide pseudo chaotic PN sequences that are relatively long with good correlation properties. Based on these results it is worth noting that the sequences based on quantized maps derive many of their statistical properties from the specific architectures used to implement them. This flexibility provides an additional level of security on top of the inherent low probability of intercept characteristics of PN sequences due to the difficulty of identify the underlying structure. Therefore the number of implementation possibilities is very high due to initial condition programmability, can be made software controlled and this new system of sequences is inherently less difficult to detect.

## REFERENCES

- [1] John G. Prokis : Digital communications. Mc. Graw Hill
- [2] G. Vidhya Krishnan, R.Nagarajan, T. Durka, M.Kalaiselvi, M.Pushpa and S. Shanmuga priya, "Vehicle Communication System Using Li-Fi Technology," International Journal of Engineering And Computer Science (IJECS), Volume 6, Issue 3, pp. 20651-20657, March 2017.
- [3] J.Chandramohan, R.Nagarajan, K.Satheeshkumar, N.Ajithkumar, P.A.Gopinath and S.Ranjithkumar, "Intelligent Smart Home Automation and Security System Using Arduino and Wi-fi," International Journal of Engineering And Computer Science (IJECS), Volume 6, Issue 3, pp. 20694-20698, March 2017.
- [4] G.Heidari-Bateni,C.D. Mc-Gillem, "Chaotic sequences for spread spectrum: An alternative to PN sequences" Proc. IEEE ICWC- 92437 C 440,1992
- [5] J.Chandramohan, R.Nagarajan, M.Ashok kumar, T.Dineshkumar, G.Kannan and R.Prakash, "Attendance Monitoring System of Students Based on Biometric and GPS Tracking System," International Journal of Advanced Engineering, Management and Science (IJAEMS), Vol-3.Issue-3, pp. 241-246, Mar. 2017.
- [6] R.Nagarajan, S.Sathishkumar, K.Balasubramani, C.Boobalan, S.Naveen and N.Sridhar. "Chopper Fed Speed Control of DC Motor Using PI Controller," IOSR- Journal of Electrical and Electronics Engineering (IOSR-JEEE), Volume 11, Issue 3, Ver. I, pp. 65-69, May – Jun. 2016.
- [7] Leon.D, S.Balkir,M.W. Hoffman, I. C. Perez, "Pseudo-chaotic PN sequence generators circuits for SS communication," Proc. of IEE Circuits Dev. Syst.151(6), pp. 543-550 (2004)
- [8] K. Anandhi and Dr. R. Nagarajan, "Mutex-Heart: Fail Safe Dual Chamber Cardiac Pacemaker Device with Rate Responsive Control and Cryptographic Security," IJSRD - International Journal for Scientific Research & Development. Vol. 3, Issue - 2, pp. 489-493, 2015.
- [9] Lathi, B.P. "Modern Digital and Analog Communications Systems," 3rd Edition. New York: Oxford University Press. 1998
- [10]R.Nagarajan, J.Chandramohan, R.Yuvaraj, S.Sathishkumar and S.Chandran, "Performance Analysis of Synchronous SEPIC Converter for a Stand-Alone PV System," International Journal of Emerging Technologies in Engineering Research (IJETER), Volume 5, Issue 5, pp. 12-16, May-2017.
- [11]M.Padmavathi and R.Nagarajan, "Smart Intelligent ATM Using LABVIEW," International Journal of Emerging Technologies in Engineering Research (IJETER), Volume 5, Issue 5, pp. 41- 45, May-2017.
- [12]R.Nagarajan and M,Saravanan. "Performance Analysis of a Novel Reduced Switch Cascaded Multilevel Inverter," Journal of Power Electronics, Vol.14, No.1, pp. 48-60. Jan. 2014.
- [13]Haykin,S. "Communication Systems," 4th Edition. New York: John Wiley and Sons, 2001
- [14]R.Nagarajan and M,Saravanan "Staircase Multicarrier SPWM Technique for Nine Level Cascaded Inverter," Proceedings of the International Conference on Power, Energy and Control, IEEE Press, pp. 668-675. 2013.
- [15]Y.Soobul, K.Chady, Harry, C.S.Rughoopath "Digital chaotic coding and modulation in CDMA," Proc. of IEEE Africon, pp. 841-846. 2002.
- [16]Bernard Sklar "Digital communication. Fundamentals and Applications, Prentice Hall. 2001.
- [17]R.Nagarajan, S.Sathishkumar, S.Deepika,G.Keerthan a,J.K.Kiruthika and R.Nandhini, "Implementation of Chopper Fed Speed Control of Separately Excited DC Motor Using PI Controller," International Journal of Engineering And Computer Science (IJECS), Volume 6, Issue 3, pp. 20629-20633, March 2017.
- [18]Ajeesh P. Kurian, Sadasivan Puthusserypady, Su Myat Htut, "performance enhancement of DS/CDMA system using chaotic complex spreading sequence", IEEE Trans. nn Wireless communication. 4 (3), pp. 984 - 989, 2005.
- [19]R.Nagarajan, R.Yuvaraj, V.Hemalatha, S.Logapriya, A.Mekala and S.Priyanga, "Implementation of PV - Based Boost Converter Using PI Controller with PSO Algorithm," International Journal of Engineering And Computer Science (IJECS), Volume 6, Issue 3, pp. 20479-20484, March, 2017.
- [20]Bob X. LI, Simon Haykin, "A new pseudo - noise generator for spread spectrum communication", Proc. of IEEE. Pp. 3603-3606, 1995.
- [21]Ms. C. Hemalatha, Mr. R. Nagarajan, P. Suresh, G. Ganesh Shankar and A. Vijay, "Brushless DC Motor Controlled by using Internet of Things," IJSTE - International Journal of Science Technology & Engineering, Volume 3. Issue 09, pp. 373-377, March- 2017.
- [22]Youssef.M. I, M. Zahara, A. E. Emam, and M. AbdElGhany, "Chaotic Sequence Implementation on Residue Number Spread Spectrum," International Journal of Communication, Volume 2, Issue2, 2008,
- [23]S.Suresh, R.Nagarajan, L.Sakthivel, V.Logesh, C.Mohandass and G.Tamilselvan, "Transmission Line Fault Monitoring and Identification System by Using Internet of Things," International Journal of



- Advanced Engineering Research and Science (IAERS), Vol-4.Issue-4, pp. 9-14, Apr- 2017.
- [24] C.Vladeanu, I.Banica, S.El Assad, "Periodic chaotic spreading sequences with better correlation properties than conventional sequences - BER performance analysis," Proc. of IEEE Int. Symp. On Signals, circuits and systems. Pp. 649-652, 2003.
- [25] A.Mahendran, K.Muthulakshmi and R.Nagarajan, "Triangular Multicarrier SPWM Technique for Nine Level Cascaded Inverter," International Journal of Scientific & Engineering Research, Vol.4, No.5, pp. 269-275, May-2013.
- [26] SuMyat Htut, Sadasivan Puthusserypady, "A Novel CDP DS/SS System with 2-Dimensional Ikeda map chaoticsequence," Proc. of IEEE Int. Symposium on Personal, Indoor and Mobile Radio communication. Pp. 2734-2738, 2003.
- [27] R.Nagarajan and M,Saravanan, "A Carrier - Based Pulse Width Modulation Control Strategies for Cascaded Multilevel Inverter," International Review on Modeling and Simulations (IRMOS), Vol 6.No1, pp-8-19, Feb. 2013.
- [28] C.Vladeanu, I .Banica, "Performanceof Multistage Detectors for DS-CDMA Systems," Proc of IEEE-ICT. Pp. 35-39, 2001.
- [29] S. Chandrasekar and Gian Carlo Montanari, "Analysis of Partial Discharge Characteristics of Natural Esters as Dielectric Fluid for Electric Power Apparatus Applications," IEEE Transactions on Dielectrics and Electrical Insulation Vol. 21, No. 3, pp.1251-1259 June 2014.
- [30] R.Nagarajan and M, Saravanan, "Comparison of PWM Control Techniques for Cascaded Multilevel Inverter" International Review of Automatic control (IRACO), Vol.5, No.6, pp. 815-828. Nov. 2012.