

Comparative Analysis of Free Space Optics and Single Mode Fiber

Pinky Vishwakarma, Jayprakash Vijay

Department of Electronics and Communication Engineering, Swami Keshvanand Institute of Technology, Management and Gramothan, Jaipur, Rajasthan, India

Abstract—In this paper we have done comparative analysis of free space optics and single mode fibre optical channels system. Performance study is done for variable ranges 1km, 50km and 100km for the FSO and SMF channels. Single Mode Fiber and Free Space Optical Channel is observed that maximum Q factor, minimum bit error rate and signal power. FSO requires no licensing or frequency synchronization. It also provides the transmission of data with unlimited bandwidth. Results expose the ability of improving the Q factor by using these channels and the optimum effect concluded at (1km) length of optical rang by using the FSO channel i.e. the quality factor and signal power were increased to reach (1943) and (22.46dBm) respectively and MIN. BER is zero.

Keywords—Optic communication system, Single Mode Fibre and Free Space optics (FSO).

I. INTRODUCTION

A fiber optic system consists of transmitting device that an electrical signal converted into a light signal, an optical fiber cable that carries the light, and at the receiver end that accepts the light signal then converts it back into an electrical signal [1]. Optical communications systems can be divided into a two types are guided and unguided. The guided optical communication systems currently use in optical fibers and it generally used term for them is fiber-optic communication systems In the case of unguided optical communication systems, the optical beam emitted by the transmitter propagated through space, equivalent to free-space optical communication (FSO) [2].

FSO is a latest technology in communication system that uses light beam propagate from the transmitter through Free Space to transmit data and received at the other side of the two point communication system [3]. FSO is line of sight technology that uses the invisible beams light to supply the optical bandwidth connection that can be send and receive up to 2.5Gbps of data, voice and video communication [4]. It can be consider as an Optical Fiber replacement particularly when the physical connections are unfeasible due to several considerations.

FSO can provide high speed point to point or point to multipoint communication which is difficult to communicate using Radio over Fiber (ROF) technology such as optical fiber [5]. It is implemented using a laser device which can be mounted inside buildings or offices and basically consists of an optical transceiver with a laser transmitter and receiver end to provide full duplex capability [6].

In wireless communication, it has many drawbacks such as bandwidth regulations, high data and power limiting etc. Otherwise FSO has main advantages are no licensing requirements or tariffs for link operation, absence of radio frequency radiation hazards, no need of road digging as in the case of optical fiber, large bandwidth which enables high data rates and low power consumption [7].

In fiber-optic communication, a single-mode optical fiber (SMF) is an optical fiber deliberate to bear light only directly down the fiber the transverse mode. These modes define the way the wave travels through space the find out the wave is distributed in to the space. Waves can have the different frequencies in a same mode. This is the case in single-mode fiber now it is defined that different frequencies, but of the same mode, which means that they are distributed in space in the same way but they gives us a single ray of light [8].

Free Space Optics (FSO) communications meaning that the transmission of modulate visible or infrared beams throughout the atmosphere to obtain optical communications [9]. FSO is shown in Figure 1. Demonstrates a typical free space optical link, rather than through a conductor such as a wire or fiber and through a waveguide of some sort. Another important attribute of FSO is that it is untouched by electromagnetic interference and radio frequency interference and the other unwanted signal which increasingly rises in radio based communication systems. The application of FSO systems are used in disaster recovery and for temporary connectivity while cabled networks are creature deployed. Free space optical communication is only effected by atmospheric distortion such as attenuation turbulence and scattering effects. FSO will become most secure, license free and high speed medium of data transmission [10].

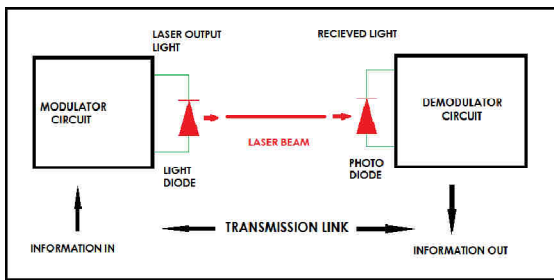

Fig. 1: An Overview of Free Space Optics FSO System

II. SYSTEM MODEL IN OPTISYSTEM

Transmission performance analysis of two different channel in optical communication systems. In this paper we have use OptiSystem software is developed by optiwave to perform complex optical communication simulation. The OptiSystem software is appropriate to be used to model and simulate fiber optic system and free space optic system FSO. It provides an undemanding user interface which is common to many other electrical engineering tools. The design was then improved by expanding the optical transmitter and receiver with specific two channel single mode fiber, free space optic.

The proposed block diagram to simulate transmission system with FSO channel and SMF channel is shown in figure 2. Consist of optical transmitted to generate optical signals supplies input signal with 750 nm, 1350 nm, 1550 nm wavelength and input power of 10 dBm with a non-return-zero pseudorandom binary sequence, divider distributed power into the two channel, optical receiver has cutoff frequency is 0.75 Bit rate Hz and eye diagram analyzer is used to study the output signal and figures will be processed as images and measuring the Q factor, BER and received power.

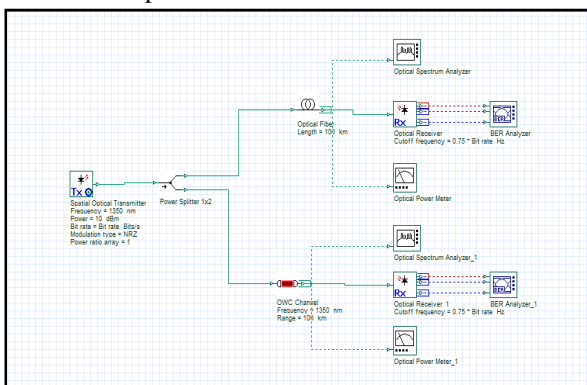

Fig.2: Optical Communication System

III. RESULT AND DISSECTION

In this paper, the performance analysis of an optical communication system with Free Space Optics (FSO) and Single Mode Fiber (SMF) in weak atmospheric

turbulence has been analyzed. Comparison is made in terms of Q factor, BER and received optical power.

The design is then improved by expanding the optical transmitter and receiver with specific two channel single mode fiber and free space optic. Consist of optical transmitter to generate optical at 750 nm, 1350 nm, 1550 nm wavelengths and input power of 10dBm. Table 1 below shows the performance analysis of SMF at different visibility or distance for different wavelengths and table 2 shows the performance analysis of FSO at different visibility or distance for different wavelengths.

Table 1

Q Factor, Ber and Received Signal Power at Visibility For Different Wavelengths of Smf.

Visibility		750 nm	1350 nm	1550 nm
1 Km	Q factor	0	340.5	349
	Bit error rate	1	0	0
	power(dbm)	-100	1.12	1.127
50 Km	Q factor	0	16.003	15.95
	Bit error rate	1	$6.02e^{-58}$	$1.00e^{-57}$
	Power	-100	-8.67	-8.67
100 Km	Q factor	0	2.701	8.05
	Bit error rate	1	0.00327	$4.01e^{-17}$
	Power(dbm)	-100	-18.67	-18.67

Table 2

Q Factor, Ber and Received Signal Power at Visibility For Different Wavelengths of Fso.

Visibility		750 nm	1350nm	1550nm
1 Km	Q factor	2134	1996	1943
	Bit error rate	0	0	0
	power(dbm)	28.77	23.66	22.46
50 Km	Q factor	78.94	93.55	102.94
	Bit error rate	0	0	0
	Power	-11.51	-10.31	-11.5
100 Km	Q factor	42	37.22	32.2
	Bit error rate	0	$1.39e^{-31}$	$1.11e^{-21}$
	Power(dbm)	-11.22	-16.33	-17.53

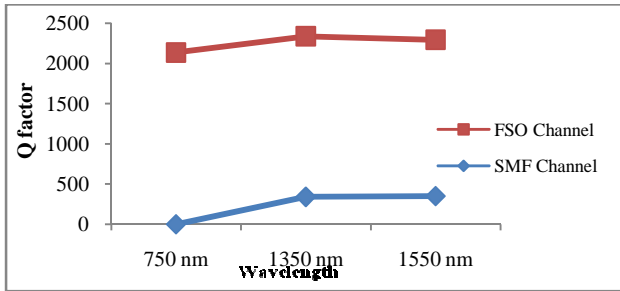

Fig.3: Q factor Vs wavelengths using two different channel at 1 km

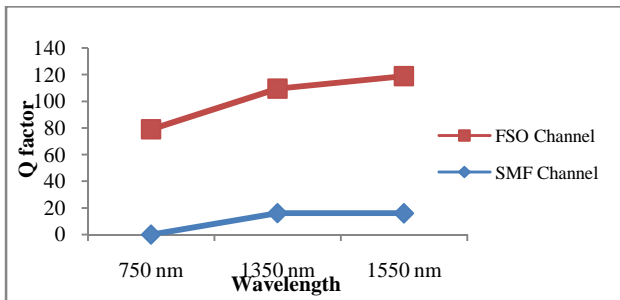

Fig.4: Q factor Vs wavelengths using two different channel at 50 km

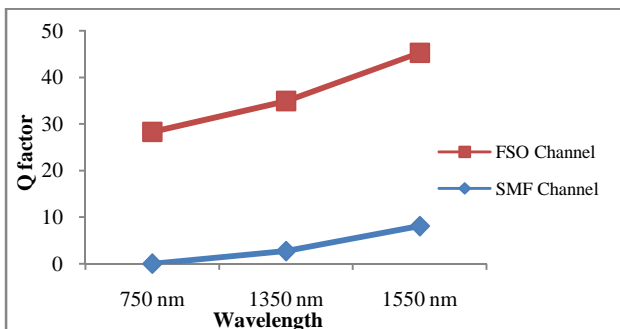

Fig.5: Q factor Vs wavelengths using two different channel at 100 km

The system performance can be evaluated in many ways such as by analyzing the BER and Q-factor. BER can be said to be the ratio of the number of bit errors detected in the receiver and the number of bits transmitted. Bit errors occur as the result of incorrect decisions being made in a receiver due to the presence of noise (unwanted signals) on a digital signal. Typically, as a quality factor, Q is a one of the important indicators to determine the optical performance by which to characterize the BER Fig. 3, fig. 4 and fig. 5 show Q factor Vs wavelengths using two different channels at 1 km, 50 km and 100 km respectively. At a visibility 1km for FSO channel Q factor 1943, received power 22.46 dBm and BER is zero while we have observed for SMF channel Q factor 349, received power 1.127 dBm and BER is zero.

At a visibility 50 km for FSO channel Q factor 102.94, received power 11.5 dBm and BER is zero while we have observed for SMF channel Q factor 15.97, received signal power 8.67dBm and BER is $1.00e^{-57}$. At a visibility 100 km for FSO channel Q factor 37.22, received power -

16.33dBm and BER $1.39e^{-30}$. For SMF channel Q factor 2.701, received power -18.67dBm and BER 0.00327. From all above result for SMF and FSO it is observed that FSO gives the better quality factor in the absence of pointing error at all the distance in comparison to SMF.

IV. CONCLUSION

In this research study two optic communication channels was the conclusion of the results obtained through the use of program optisystem software and by reading obtained from the tables and figure shapes. The above found that the ability rising each channel moving up along the optical path and also proved by seen from above results, that the channel FSO is give the best results i.e. reduced the value of minimum bit error rate and increased the values of quality factor and received power when compared with other channels SMF channel. From all above result for SMF and FSO it is observed that FSO gives the better quality factor in the absence of pointing error at all the distance in comparison to SMF.

REFERENCES

- [1] Prachi Sharma¹, Suraj Pardeshi², Rohit Kumar Arora³, Mandeep Singh⁴ " A Review of the Development in the Field of Fiber Optic Communication Systems" International Journal of Emerging Technology and Advanced Engineering Website: www.ijetae.com .Journal, Volume 3, Issue 5, May 2013.
- [2] Scott Bloom, Eric Korevaar, John Schuster and Heinz Willebrand "Understanding the performance of free-space optics," Journal of optical networking, vol. 2, pp 34-37, Jun.2003.
- [3] Nazmi A. Mohammed, Amr S. El-Wakeel and Mostafa H. Aly, " Pointing Error in FSO Link under Different Weather Conditions", International Journal of Video & Image Processing and Network Security IJVIPNS-IJENS vol. 12, No: 01, p.p 6-9, Feb. 2012.
- [4] Ha Duyen Trung, et.al "Pointing Error Effects on Performance of Free-Space Optical Communication Systems using SC-QAM Signals over Atmospheric Turbulence Channels" International Journal of Electronics and Communications , pp.869-876 ,5 April 2014.
- [5] Ehsan Bayaki, Robert Schober and Ranjan K. Mallik "Performance Analysis of MIMO Free-Space Optical Systems in Gamma-Gamma Fading" IEEE Transactions on Communications, Vol. 57, Issue 11, pp.3415-3424, November 2009

- [6] Sanjeev Dewra, R.S.Kaler “Performance Evaluation of an Optical Network based on Optical Cross Add Drop Multiplexer” *Opticheskiy Zhurnal* , Vol. 80, pp.46-50, 15 January 2013.
- [7] Bijayananda Patnaik, P.K. Sahu , “Optimized Hybrid Optical Communication System for First Mile and Last Mile Problem Solution of Today’s Optical Network” *Sci Verse Science Direct 2nd International Conference on Communication, Computing and Security*, pp.723-730, 2012.
- [8] Vishal Sharma, Naresh Kumar “Improved Analysis of 2.5 Gbps Inter-satellite link (ISL) in Inter-satellite Optical-Wireless Communication (IsOWC) system” *Optics Communications* 286, pp.99–102, 2013.
- [9] Murat Uysal, Jing (Tiffany) Li, and Meng Yu, “Error Rate Performance Analysis of Coded Free-Space Optical Links over Gamma-Gamma Atmospheric Turbulence Channels” *IEEE Transactions On Wireless Communications*, Volume 5, Issue 6, pp.1229-1233, June 2006.
- [10] Nazmi A. Mohammed, Amr S. El-Wakeel and Mostafa H. Aly, “Performance Evaluation of FSO Link Under NRZ-RZ Line Codes, Different Weather Conditions and Receiver Types in the Presence of Pointing Errors”, *The Open Electrical & Electronic Engineering Journal*, vol 3, pp 28-35, March 2012.