

Modeling and Characterization of MEMS Electrostatic Energy Harvester

G.Karthik Reddy, S.Rajanendra

Asst. Professor, Dept of ECE, MLR institute of Technology, Hyderabad, Telangana, India
Asst. Professor, Dept of ECE, Sree Vidyanikethan Engineering College, Tirupathi, Andhra Pradesh, India

Abstract— In low-power wireless electronic devices, Energy harvesting generators have received increasing research interest in recent years. This paper describes the design and analysis of electrostatic transduction based MEMS energy harvester. Due to the benefit of a folded beam configuration that can be displace large dimensions and compliant in desired direction and stiffer in orthogonal direction. Since, large displacement of proof mass of energy harvester renders the enhance performance. Hence, the folded beam configuration of harvest has been modeled and designed and optimized the dimension of geometry. FEM simulations using COMSOL were conducted to evaluate the natural frequency and mode shape of the system and compared results with that of analytically calculated values. Spice circuit of harvester has been modeled and performed simulation to evaluate the output power of the harvester in LTSPICE. Parameter analysis was conducted to determine the optimal load and optimal output power.

Keywords— *Electrostatic, Folded beams, FEM, LTSPICE modeling, Energy harvester.*

I. INTRODUCTION

Battery powered various wired and wireless electronics devices require a small amount of power for their functionality. The traditional methods that were used to powering the electronics devices has large size, more cost and requires replacement or recharging batteries [1]. Vibrations, which are occurred commonly in surrounding environment and specific applications, in which sufficient vibration energy exist. By advancement of MEMS technologies, the miniaturized cost effective devices for energy conversion from ambient vibrations are superior choice [2]. An extraction of electrical power from ambient sources is generally known as energy harvesting, or energy scavenging. There are mainly three methods of MEMS energy harvesters for energy transduction, such as piezoelectric, electromagnetic and electrostatic mechanism [3]. In a piezoelectric transduction

mechanism, by exploiting the mechanical strain or relative displacement caused from applied external load into active piezoelectric material of device can be convert into an electrical energy. The output power achieved depends on an amount of strain generated in piezoelectric material, coefficient of material, thickness of material or multi-layer stack and electro-mechanical coupling coefficient. The principle of electromagnetic transduction is that the relative movement (due to external velocity) between a permanent magnet and a coil mounted on the mechanical movable element like beam produce an electricity. In case of electrostatic mechanism, electrical power is obtained by charging and discharging of capacitor plates of bias voltage and associated with mechanical vibrations. Each transduction mechanism has their own benefits and drawbacks. The electrostatic method is one of best choice, since it is well known process to realize a micro scale structure with micromachining techniques [1,2].

In this paper, electrostatic based MEMS energy harvester has been presented. One of main concern is that electrostatic harvesters require an initial polarizing voltage or charge. This can be provided by supplying the bias voltage among available methods that are electret based, floating method and work function method [4]. An In-plane overlap varying comb drive actuator has been chosen [2]. Since, it can be utilized for large displacement applications and it has compliant to desired direction and stiff in orthogonal directions. A modelling and design is presented in section II. The designed model has been analysed by performing simulations in COMSOL multiphysics and LTSPICE, results are discussed in section III.

II. DESIGN AND MODELING

A schematic of in-plane overlap varying comb drive for electrostatic MEMS energy harvester is shown in fig 1. It includes the shuttle mass associated comb fingers suspended by folded beam configuration, outer folded beams are anchored to the ground plane, stator comb fingers and trusses

allow expansion or contraction of the beams along axial direction. A ground plane is placed underneath of shuttle to avoid the vertical deflection. The modelling of electrostatic MEMS energy harvester includes the mechanical behavior, the behavior, the coupling the mechanical and electrostatic energies and finally out power extraction. The details of these modelling is discussed in this section.

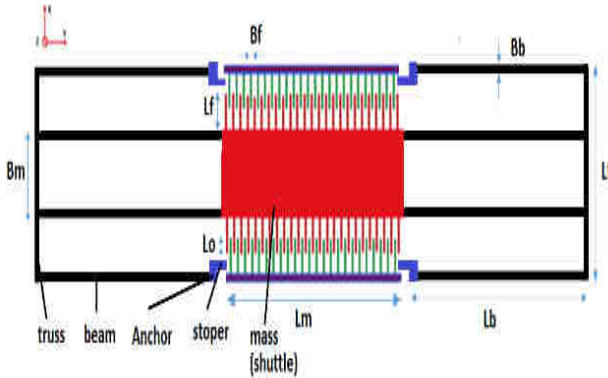

Fig.1: Schematic diagram of folded beam electrostatic energy harvester.

A. Mechanical behaviour

The spring constant of folded beam configuration is obtained from small deflection theory. Each beam is considered as a guided cantilever beam with same length and width, and assumed trusses are rigid. The equivalent spring constant for axial and lateral direction of folded beam configuration is given below [5].

$$K_x = \frac{2EhB_b^3}{L_b^3} \quad K_y = \frac{2EhB_b}{L_b} \quad (1)$$

And the stiffness ratio is :

$$\frac{K_y}{K_x} = \left(\frac{L}{b_b} \right)^2 \quad (2)$$

This beam configuration has exhibited less deflection in axial direction and strong compliant to the lateral direction and it can be provided the larger lateral deflection. Stopper is placed to avoid sticking of shuttle to the stationary elements. The natural frequency for lateral mode shape of the structure can be obtained from Rayleigh's quotient [5].

$$f = \frac{1}{2\pi} \sqrt{\frac{K_y}{M_{shuttle} + \frac{1}{2}M_{truss} + \frac{96}{35}M_{beam}}} \quad (3)$$

An assumption is made that structure undergoes only a lateral deflection in standard air environment. According to the linear fluid damping, the formula for in-plane comb drive structure is given below [2].

$$D = \frac{N_g \mu L h}{g} \quad (4)$$

B. Electrostatic behaviour

By providing bias voltage to the shuttle mass, parallel plate capacitor is formed between two adjacent comb fingers and opposite charges are distributed in each finger of parallel plate capacitor. The total capacitance of one comb-drive model is given below:

$$C = 2n\epsilon_0 \frac{h(w_0 \pm w)}{g} \quad (5)$$

The charge distribution between adjacent fingers of parallel plate capacitor produce an electrostatic force between them. The electrostatic force in axial direction is cancel each other, but the lateral direction electrostatic force is existed.

$$F_y = -\frac{1}{2} \frac{\partial C}{\partial x} V^2 = N\epsilon_0 \frac{h}{g} V^2 \quad (6)$$

C. Electro-mechanical behaviour

The equation of motion for the structure at presence of electrostatic force and external acceleration vibration with frequency of natural frequency of structure is given below.

$$m\ddot{x} + D\dot{x} + K_x x = -m\ddot{z} \quad (7)$$

In analysis of harvest, parasitic capacitance and end stop are not included.

III. RESULTS AND DISCUSSION

The dimensions of structure has been optimized to get the desired frequency and maximum output power. The in-plane overlap varying comb drive model has been designed and modelled as per dimensions listed in table 1 in COMSOL multiphysics and polysilicon has chosen as a structural material. Simulations were performed to extract the natural frequency of 667 Hz and lateral mode shape of structure, shown in figure 2. The frequency obtained from FEM simulation was well matched with analytical value according equation (3). In figure 3, shown comparison of natural frequency of system obtained from analytically and FEM simulation for varying beam length.

Table 1: List dimensions of geometry.

Parameter	dimension(μm)
beam length, L _b	3500

beam width, B_b	25
truss length, L_t	480
mass length, L_m	5010
mass width, B_m	320
finger length, L_f	250
finger width, B_f	20
finger overlapping distance, L_0	180
distance between fingers, g	5
number of fingers associated with one side of mass, n	100
thickness, h	500

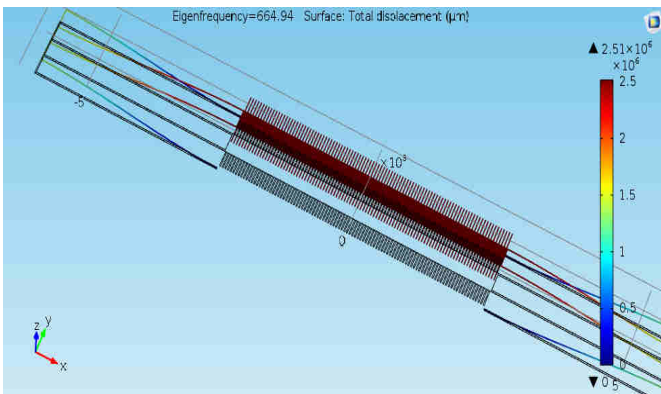

Fig.2: lateral mode shape of harvester with natural frequency of 667 HZ.

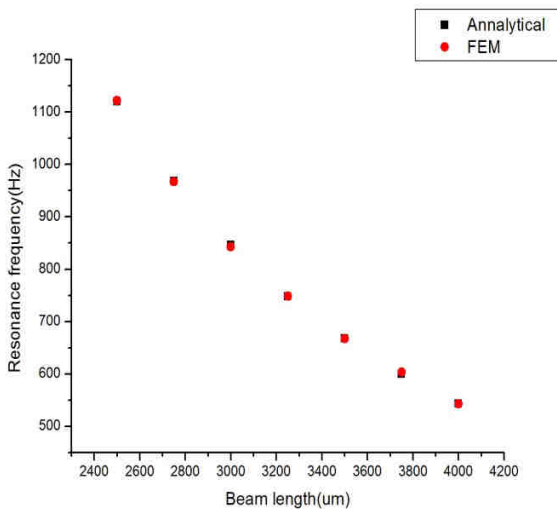

Fig.3: Natural frequency Vs. beam length obtained from analytical and FEM simulation.

A lumped model of the structure is modelled in LTSPICE, shown in figure 4. The values of spring constant (k), mass (m), damping (b), transduction coefficient were calculated using (1)-(4), respectively for the parameter values of the lumped elements.

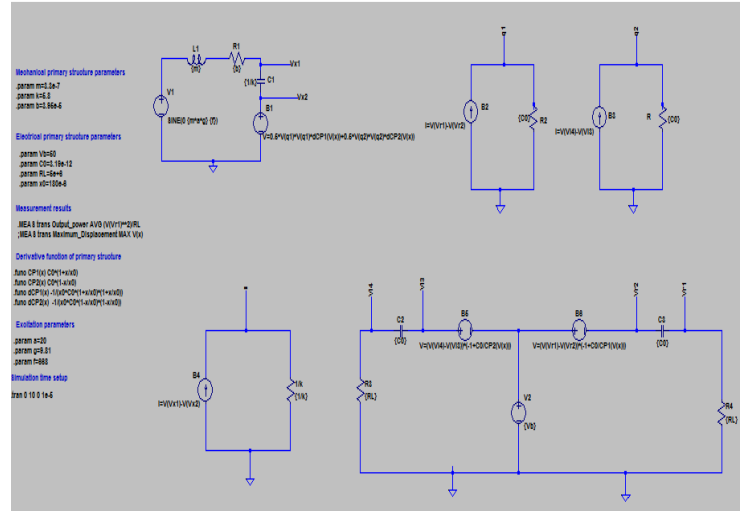

Fig.4: LTSPICE model of electrostatic MEMS energy harvester.

Bias voltage of 20 V is applied to the shuttle and load resistor of 5 MΩ to extract electric power is connected to the each stationary comb-drive. An external mechanical vibration, harmonic acceleration with frequency equal to the natural frequency, 668 Hz, was applied with an amplitude of 2 g to the electrostatic energy harvesting model. A transient simulations were conducted for above mentioned the input excitation and the outload resistance to the harvester model. The plots of maximum displacement of 40 μm and output voltage across load resistor is 0.27 V are shown in figure 5 & 6 respectively.

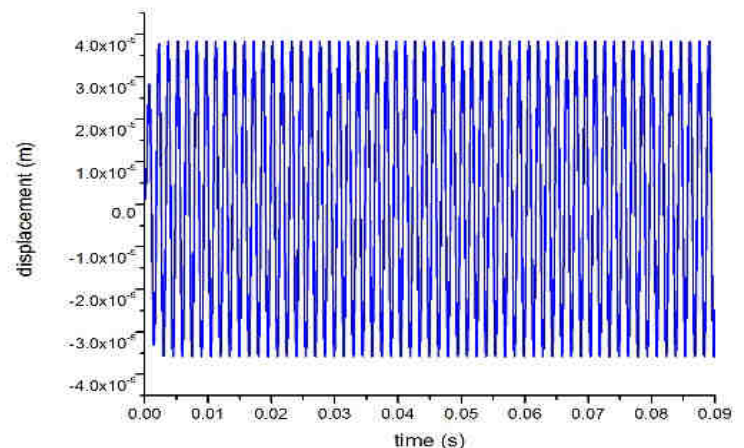

Fig.5: Displacement of proof mass of harvester for given bias voltage of 20 V, 2 g acceleration and 5 MΩ load resistance.

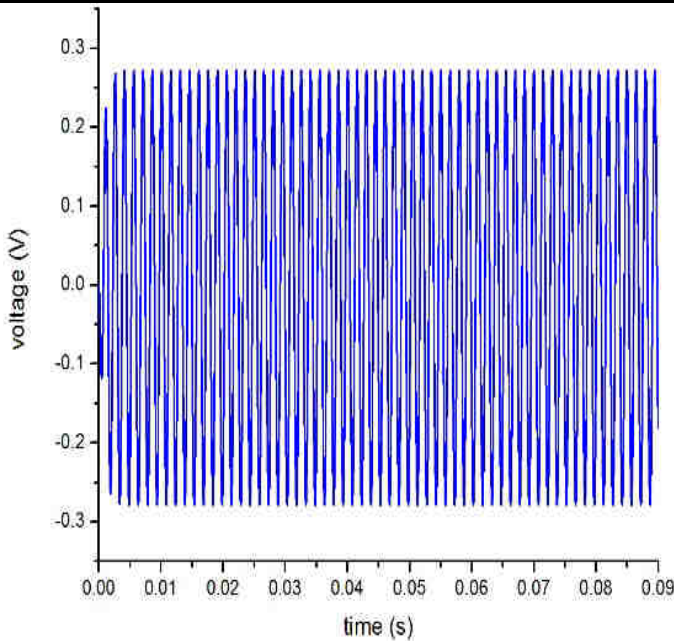

Fig.6: Voltage across load resistor harvester for given bias voltage of 20 V and 2 g acceleration.

The optimal load resistance of 75 MΩ was determined by parametric sweep of load resistance with respect to output power, shown in figure 7.

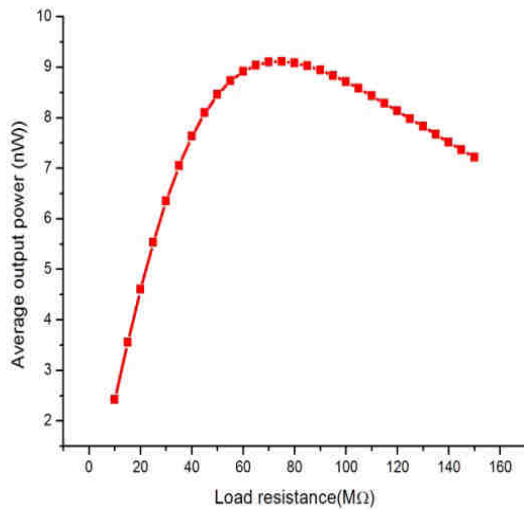

Fig.7: Average output power Vs. load resistance of harvester.

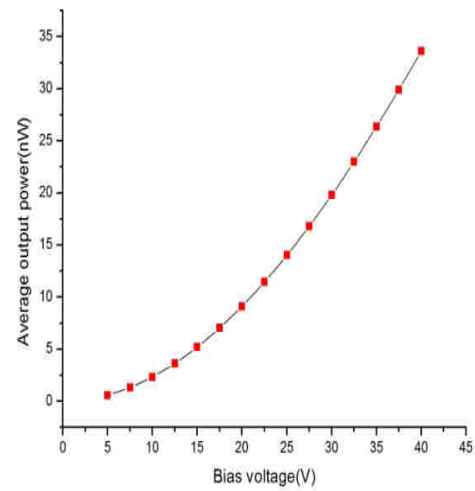

Fig.8: Average output power Vs. bias voltage of harvester.

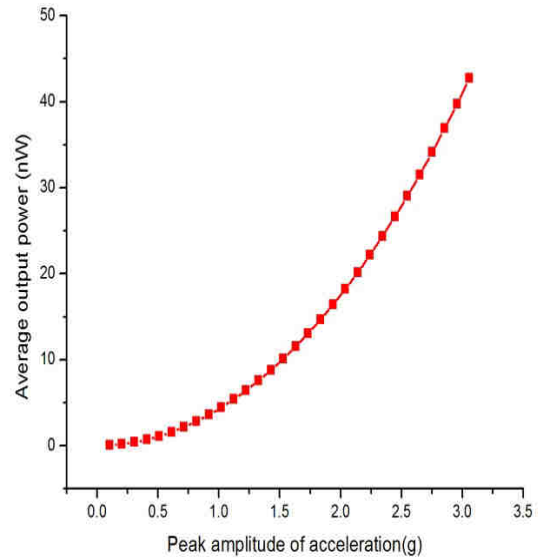

Fig.9: Average output power Vs. input acceleration of harvester.

Parametric analysis of harvester for varying the bias voltage and input acceleration were performed and observed the output average power. From figure 8 & 9, observed that output power of harvester is linearly varying with bias and input acceleration.

IV. CONCLUSION

The folded beam configuration of harvest has been modeled and designed in COMSOL and LTSPICE. FEM simulations

using COMSOL were conducted to evaluate the natural frequency and mode shape of the system and compared results with that of analytically calculated values. Spice circuit of harvester has been modeled and performed simulation to evaluate the output power of the harvester in LTSPICE. Parameter analysis was conducted to determine the optimal load and observe the output power for varying the input acceleration and bias voltage.

REFERENCES

- [1] Mitcheson, Paul D E, “ Energy Harvesting from Human and Machine Motion for Wireless Electronic Devices”, *Proceedings of IEEE*,2008,1457-1486
- [2] Roundy, Paul K.Wright, Kristofer SJ Pister, “Micro-Electrostatic Vibration to Electricity Convertors”, *International Mechanical Engineering Congress and Exposition, American Society of Mechanical Engineers(ASME)*,2002.
- [3] Beeby S.P,M.J Tudor, N.M. White, “Energy Harvesting Vibration sources for Microsystems Application”, *Measurement Science and Technology*,2006, 175-195.
- [4] Varpula Aapo, Sampon J.Laakso et al. “Harvesting Vibrational Energy using Material work functions”, *Scientific Reports* 4 (2014).
- [5] Legtenberg Rob, A.W. Groeneveld, M.Elwenspoek, “Comb-drive Actuators for large displacements”, *Journal of Micromechanics and Micro Engineering*,1996,320-310.