

Voltage profile Improvement Using Static Synchronous Compensator STATCOM

Mohammed Y. Suliman

Technical Power Engineering Dept., Northern Technical University, Baghdad, Iraq

Abstract—Static synchronous compensator (STATCOM) is a regulating device used in AC transmission systems as a source or a sink of reactive power. The most widely utilization of the STATCOM is in enhancing the voltage stability of the transmission line. A voltage regulator is a FACTS device used to adjust the voltage disturbance by injecting a controllable voltage into the system. This paper implement Nruro-Fuzzy controller to control the STATCOM to improve the voltage profile of the power network. The controller has been simulated for some kinds of disturbances and the results show improvements in voltage profile of the system. The performance of STATCOM with its controller was very close within 98% of the nominal value of the busbar voltage.

Keywords— FACTS, STATCOM, VSI, d-q theory, park transformation, FLC, Sinusoidal Pulse Width Modulation (SPWM).

I. INTRODUCTION

Power quality is defined of electrical limits that permit the part of equipment to function in its intended manner without loss of performance or life expectancy. The electrical device like electric motor, a transformer, generator, computer, printer, communication equipment, or a house hold machine. All of these devices react negatively to power quality, depending on the severity of the problems. Reactive power cannot be transmitted across large power angle even with essential the magnitude of voltage gradient [1]. instability of Voltage may cause partial or complete interruption in the power system. STATCOM is a voltage-source inverter (VSI) based shunt device generally used in transmission and distribution system to improve power quality. The main advantage of STATCOM is that, it has a very sophisticated power electronics based control which can efficiently regulate the current injection into the distribution bus [2]. The second advantage is that, it has multifarious applications, e.g. I. cancelling the effect of poor load power factor, ii. Suppressing the effect of harmonic content in load currents, iii. Regulating the voltage of distribution bus against sag/swell etc., compensating the reactive power requirement of the load and so on [3]. STATCOM with an energy source on the

DC side, it is advisable to control both the magnitude and phase angle of the injected voltage by the VSC in order to control the active power and reactive power output. A shunt compensator enables to mitigate voltage fluctuations at the point of common coupling (PCC) [4].

II. COMPENSATION AND VOLTAGE REGULATION

The principle and theoretical effects of shunt reactive power compensation in AC system for voltage regulation are shown in figure 1. This includes a source (V_1), a power line and a typical inductive load. Figure 1a, shows the system without compensation and it is related to the phasor diagram. In the phasor diagram, the phase angle of the current has been related to the load side, this means that the active current (I_p) is in phase with the load voltage (V_2). Since the load assumed inductive requires reactive power for suitable operation and hence, the source must supply it; thus increasing the current from the generator and through power lines. If reactive power is supplied near the load, the line current can reduce power losses and improve voltage regulation at the load terminals [5]. This can be done in three ways: **1)** with a capacitor [6]; **2)** with a voltage source inverter [7]; or **3)** with a current source inverter [8]. In figure 1b, a current-source device is used to compensate the reactive component of the load current by inject/absorb current (I_C) to/from system. As a result, the system voltage regulation is improved and the reactive current component from the source is reduced or almost eliminated. If the load needs leading compensation, then an inductor would be required. In addition, a current source or a voltage source can be used for inductive shunt compensation.

The STATCOM is providing voltage support under large system disturbances during which the voltage excursions would be well outside of the linear operating range of the compensator. The main advantage of using voltage or current-source Var generators (instead of inductors or capacitors) is that the reactive power generated is independent of the voltage at the point of connection as shown in figure 2 [9].

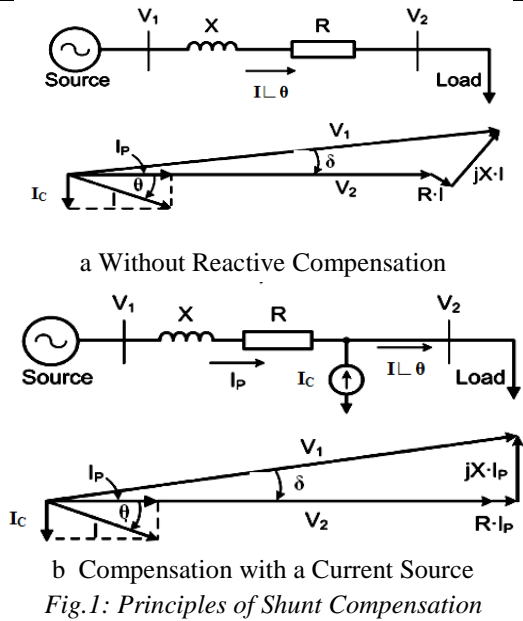

Fig.1: Principles of Shunt Compensation

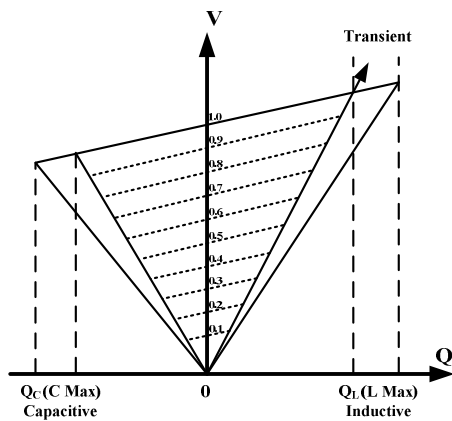

Fig.2: Q-V characteristics of the STATCOM

The STATCOM connected between the source and load as shown in figure 3.

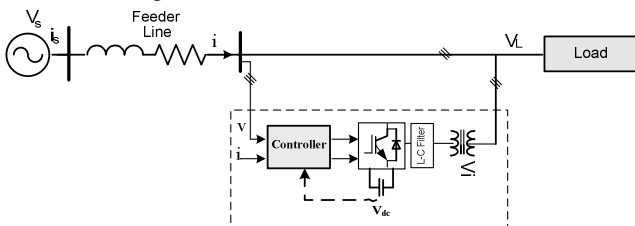

Fig.3: Fundamental connection of STATCOM

III. MEASURING LINE VOLTAGE AND REACTIVE POWER

For measuring active and reactive power, d-q theory was used. This theory is based on time-Domain, and it is valid for operation in steady-state or transient state, as well as for generic voltage and current power system waveforms, allowing to control the active power filters in real-time. Another important characteristic of this theory is the simplicity of the calculations, which involves algebraic calculation exception to the need of separating the mean

and alternated values of the calculated power component [10]. The d-q theory performs a transformation known as “park transformation” of a stationary reference system of coordinates a-b-c to d-q rotating coordinates[11].The transform applied to time-domain voltages in the natural frame (i.e. v_a, v_b and v_c) is as follows:

$$\begin{bmatrix} v_d \\ v_q \\ v_0 \end{bmatrix} = \frac{2}{3} \begin{bmatrix} \cos(\varnothing) & \cos(\varnothing - \frac{2\pi}{3}) & \cos(\varnothing + \frac{2\pi}{3}) \\ -\sin(\varnothing) & -\sin(\varnothing - \frac{2\pi}{3}) & -\sin(\varnothing + \frac{2\pi}{3}) \\ 1 & 1 & 1 \end{bmatrix} \begin{bmatrix} v_a \\ v_b \\ v_c \end{bmatrix} \quad (1)$$

$$\begin{bmatrix} i_d \\ i_q \\ i_0 \end{bmatrix} = \frac{2}{3} \begin{bmatrix} \cos(\varnothing) & \cos(\varnothing - \frac{2\pi}{3}) & \cos(\varnothing + \frac{2\pi}{3}) \\ -\sin(\varnothing) & -\sin(\varnothing - \frac{2\pi}{3}) & -\sin(\varnothing + \frac{2\pi}{3}) \\ \frac{1}{2} & \frac{1}{2} & \frac{1}{2} \end{bmatrix} \begin{bmatrix} i_a \\ i_b \\ i_c \end{bmatrix} \quad (2)$$

$$\varnothing = (\omega t + \theta) \quad (3)$$

Where \varnothing is the angle between the rotating and fixed coordinate system at each time and θ the phase shift of the voltage. Then the active and reactive power compensated calculated by:

$$p = V_d I_d + V_q I_q \quad (4)$$

$$q = V_d I_q - V_q I_d \quad (5)$$

The measured voltage is:

$$v = \sqrt{v_d^2 + v_q^2} \quad (6)$$

IV. CONTROL SCHEME OF STATCOM

The block diagram of STATCOM control system is shown in Figure 4. The three phase line voltages are sensed then filtered to eliminate high frequency noise and the quadrature voltage components (v_d and v_q) the are calculated by park transformations. The measured voltage is calculated and works as a feedback for the closed loop control system. The measured voltage is compared with the reference voltage of the busbar (set point) v_{ref} to generate error signals v_{error} . This error signal is processed in the controller where:

$$v_{error} = v + V_{ref} \quad (7)$$

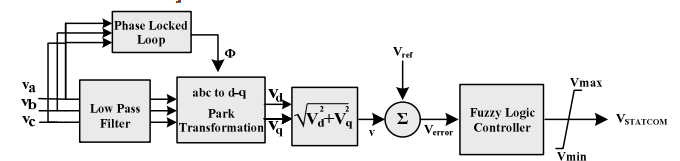

Fig.4: Block diagram for STATCOM control system

V. FUZZY CONTROL SYSTEM

Fuzzy systems are suitable for uncertain or approximate reasoning, especially for the system with mathematical model that is difficult to derive. Fuzzy logic controllers play an important role in many practical applications. There are many fuzzy inference mechanisms in fuzzy logic control system from which Takagi-Sugeno is chosen in this study. The Artificial Neural Network (ANN) will be used in this study to tune the membership functions of the TS fuzz-like-PI controller. The TS fuzzy controller have a highly non-linear variable gain controller. it produces wide variations of the controller gain. Arbitrary selection of these parameters may lead to an adequate system response or instability [12]. First the controller build using mamdani-type then transfer it to TS fuzzy type to get a better system response by using Neuro-Fuzzy system to adapt the fuzzy system parameters and rules by employing ANN learning algorithm. Since it combines the fuzzy qualitative approach with the adaptive learning capabilities of the neural network, such a system can be trained without a great amount of expert knowledge usually required for the standard fuzzy logic [13]. As a result, the rule-base can be reduced.

The parameters of the input and output membership functions are to be determined during the training stage. The designed Fuzzy system consists of five layers, each layer has either fixed nodes (that have no parameters to be tuned) that have parameters to be tuned during training. The output of the five layers which emulate the fuzzy system design steps is given as follows, referring to [14] for more details. The objective of the learning algorithm is to adjust the parameters of the input and output membership functions so that the ANFIS output best matching the training data. A hybrid learning strategy (Gradient Descent-GD and Lease Squares Estimate-LSE) is applied to identify the network parameters. The GD method updates the antecedent membership function parameters. In this work The input universe of discourse is split into 5 gaussian membership function with 50% overlapping, therefore, for two inputs (error and Δ error), 25-control rule consequent linear functions need to be determined as shown in Figure 5. To tune the TS rules using ANFIS, two sets of data are to be generated. The input data is a vector of the V_{error} and ΔV_{error} the output m the modulation index. Figure6 shows the validation test of Fuzzy logic system. This procedure is performed using the GUI of ANFIS file included in the MATLAB/FUZZY Logic Toolbox.

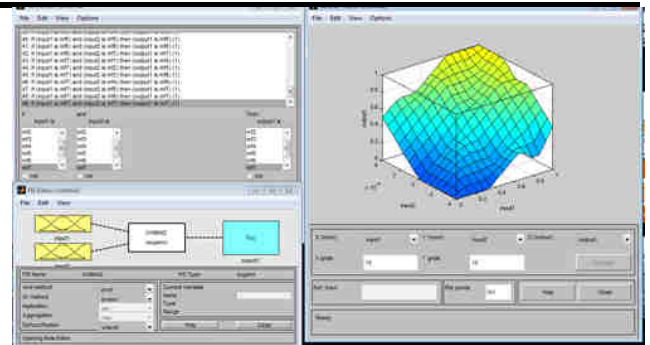

Fig.5: Fuzzy logic validation test and surface

VI. SIMULATION STUDY

System consists of feeder with two branches changeable load. the STATCOM system installed in busbar 2 (BB2) to compensate the voltage in BB2. the test start by change the load and measure the load voltage at BB2 without compensation as shown in figure 10. From the result it can be notice that the drop voltage increased proportionally with increasing the load, the maximum drop was 0.94 pu between 0.6 and 0.8 sec. Figure 11 shows the action of STATCOM to compensate the load voltage where the voltage at BB2 was restored and mitigate the drop voltage from 0.94 to 0.985 pu, this compensation done by inject compensated voltage $V_{STATCOM}$ with respect to the phase voltage as shown in Figure 12. Figure 13 shows the p-v curve, it can notice that the voltage with STATCOM more stable and enhanced the stability margin. To investigate the performance of the proposed intelligent controller under the step change of the load condition, a PI controller is used for the sake of comparison. Figure 14 shows the results of the system response to step change in rms of the line voltage. From the results it is clear that the Fuzzy controller has a smoother in response and reaches the steady state faster than the conventional PI controller.

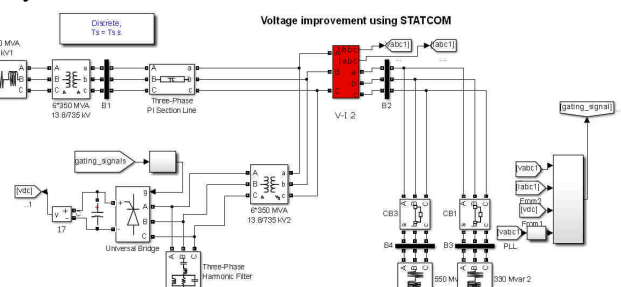

Fig.6: System model for simulation

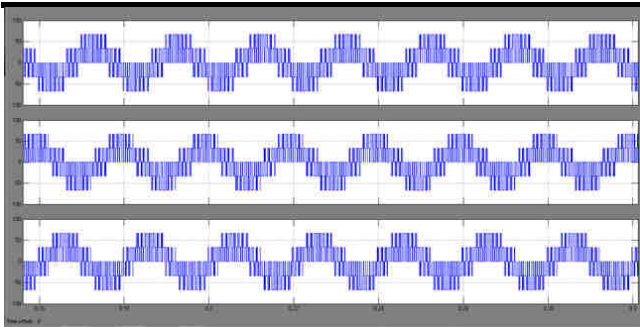

Fig.7: The 3-ph phase waveforms output of the inverter

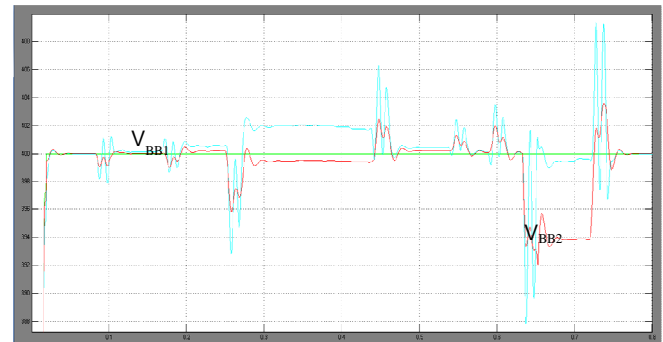

Fig.11 The BB2 voltage with compensation

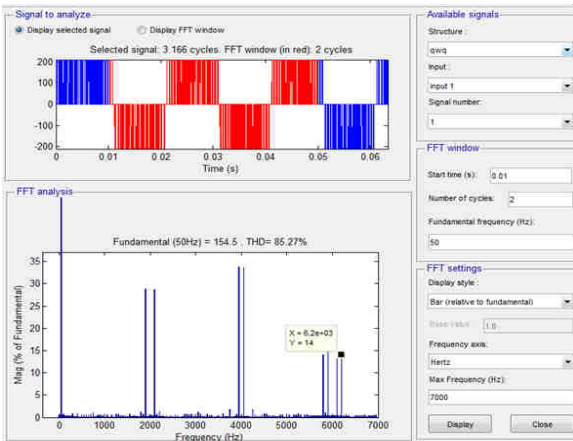

Fig.8: Fourier analysis of the output inverter

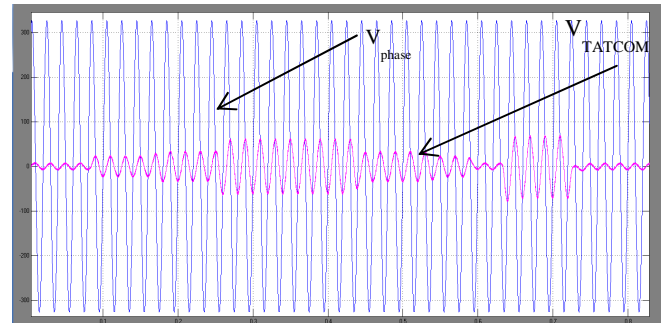

Fig.12 The injected compensated voltage $V_{STATCOM}$ versus phase voltage

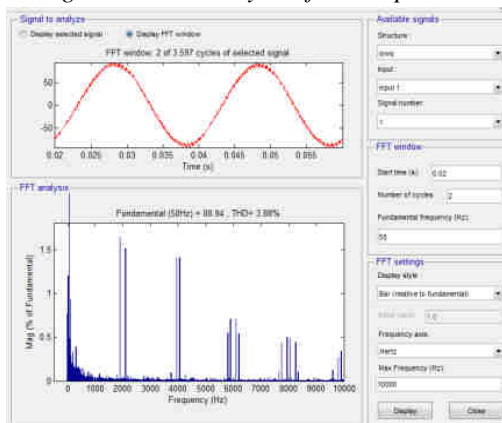

Fig.9: Fourier analysis of the line current after STATCOM voltage injected

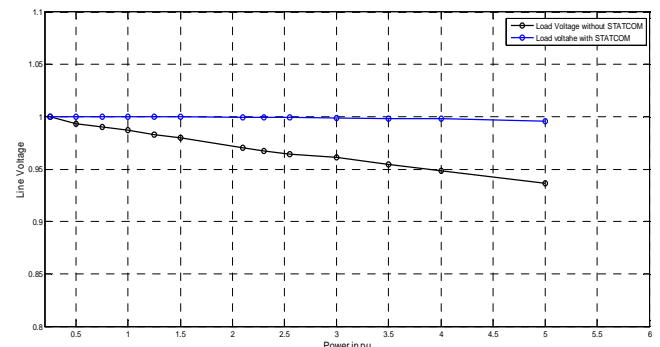

Fig.13 P-V curve of the system

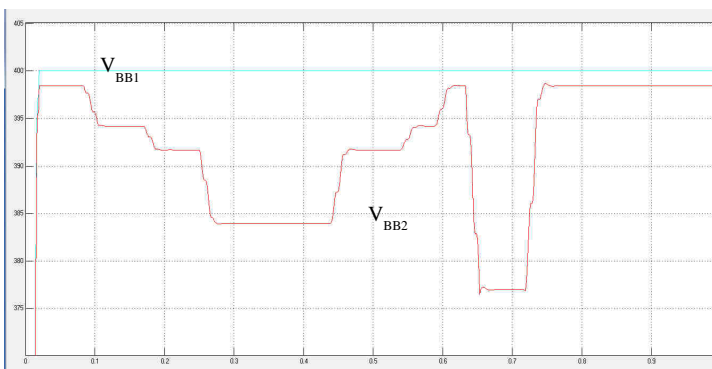

Fig.10: The BB2 voltage without compensation

VII. CONCLUSION

In this paper a three phase PWM STATCOM with its controller has been inserted in the feeder system and some disturbances has been studied via modeling and simulation. The simulation results have shown that the STATCOM with the proposed controller can improve the voltage profile of the power system during the disturbances. A STATCOM model has been developed with all the necessary components and controllers in order to demonstrate its effectiveness in maintaining a fast voltage regulation at load bus bar. The simulation results were compared with and without compensation. The results have proved the ability of the STATCOM to restore the load voltage for increased the load with satisfactory performance. The performance of STATCOM with its controller was very close (within 98%) of the nominal value of the busbar voltage. In these tests the conventional PI controller has been used for the

seek of comparison. Also controller algorithm is used to control the STATCOM for voltage profile improvement. The tuning algorithm is performed off-line employing the concept of Neuro-Fuzzy System. The rules defined by training the change of error for voltage to initiate the tuning process. The small computation time of the controller has the potential of implementation in real time. The simulation results show that the proposed controller can provide an adequate performance for the STATCOM operation. Fuzzy controller algorithm is used to control the STATCOM for voltage profile improvement. the results show that the used controller smoother and fast response compared with the conventional PI controller.

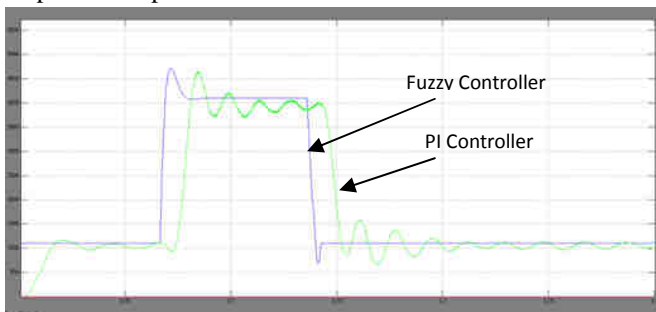

Fig.14 The line voltage versus injected compensated voltage

REFERENCES

- [1] E. Acha, C. Fuerte, H. Ambriz and C. Angeles-Camacho, "FACTS Modeling and Simulation in Power Networks", *John Wiley & Sons Ltd*, pp. 21-23, 2004.
- [2] R. Mathur and R. Varma, "Thyristor-based FACTS Controllers for Electrical Transmission Systems", *Wiley-IEEE Press Power engineering*, Piscataway, NJ, Mar, pp 34-36, 2002
- [3] Hingorani and L. Gyugyi, "Understanding FACTS, Concepts and technology of flexible AC transmission systems", *IEEE Press*, pp. 172-174, 2000
- [4] Bo Yang, Guang Zeng, Yanru Zhong and Zhonglai Su, "Cascade STATCOM step wave optimization based on PSO", *IEEE International Power Electronics and Application Conference and Exposition*, shanghai, china, pp1445-1450, 2014.
- [5] Hailian Xie, Angquist Lennart, and Hans Peter Nee, "Investigation of StatComs With Capacitive Energy Storage for Reduction of Voltage Phase Jumps in Weak Networks," *IEEE TRANSACTIONS ON POWER SYSTEMS*, Vol. 24, No. 1, FEB. 2009.
- [6] R. Vanitilaand M. Sudhakaran, "Differential Evolution algorithm based Weighted Additive FGA approach for optimal power flow using multi-type FACTS devices", *Emerging Trends in Electrical Engineering and Energy Management Conference (ICETEEEM)*, Chennai, pp. 198-204, 2012.
- [7] Liu Qing and Wang Zengzeng, "Coordinated design of multiple FACTS controllers based on fuzzy immune co-evolutionary Algorithm", *IEEE Power & Energy Society General Meeting*, Calgary, AB, pp. 1-6, 2009.
- [8] S. Panda, and N. P. Padh., "Comparison of particle swarm optimization and genetic algorithm for FACTS-based controller design", *Appl. Soft Compute.*, vol.8, no.4, pp. 1418-1427, 2008.
- [9] Anulal A. M, Archana Mohan and Lathika B. S, "Reactive power compensation of wind-diesel hybrid system using STATCOM with Fuzzy tuned and ANFIS tuned PID controllers", *International Conference on Control Communication & Computing India (ICCC)*, *IEEE Conference*, 19-21 Nov, 2015, pp. 325-330, 2015.
- [10] Ghias Farivar, Branislav Hredzak and Vassilios G. Agelidis, "Decoupled Control System for Cascaded H-Bridge Multilevel Converter Based STATCOM", *IEEE Transactions on Industrial Electronics*, Volume: 63, Issue1, pp. 322-331, 2016.
- [11] V. Ponananti and B. Rajesh Kumar, "Three-phase statcom controller using D-Q frame theory for a three-phase SEIG feeding single phase loads", *Electronics and Communication Systems (ICECS)*, *2nd International Conference IEEE Conference*, Coimbatore, India, 2015, 26-27 Feb., pp.926-931, 2015.
- [12] Mohammed Y. Suliman and Sameer Sadoon Al-Juboori, "Design of Fast Real Time Controller for the Dynamic Voltage Restorer Based on Instantaneous Power Theory", *International Journal of Energy and Power Engineering*, Vol 5, Issue 2-1, pp. 1-6, 2016.
- [13] Farrag M. E. A, G. A. Putrus, "Design of adaptive Neuro-Fuzzy inference controller for a transmission system incorporating UPFC", *IEEE, Transaction on Power Delivery*, Vol. 27, Issues: 1, pp. 53-61, 2012.
- [14] Farrag M. E. A., Putrus G. A. and Ran L, "Artificial Neural Network Based Adaptive Takagi-Sugeno Fuzzy Like PI Controller For Optimal UPFC Performance" *IEEE 7th International Conference on Intelligent Engineering Systems*, Assiut, Egypt, pp. 312-316, 2003.