

# Comparative Analysis of PID and NARMA L2 Controllers for Shell and Tube Heat Exchanger

Vuppala John Venkanna, Ginuga Prabhaker Reddy, V Ramesh kumar

Department of Chemical Engineering, University College of Technology, Osmania University, Hyderabad, Telangana, India

**Abstract**—The application of this paper firstly simplified mathematical model for heat exchanger process has been developed and used for the dynamic analysis and control design. A conventional PID controller and Advanced Artificial Neural Network NARMA L2 Controller for Shell and Tube heat exchanger is proposed to control the cold water outlet temperature and test the best efficiency of NARMA L2 and PID controller. The control problem formulated as outlet cold water temperature is controlled variable and the inlet hot water temperature is manipulated variable the minimum possible time irrespective of load and process disturbances. Simulation and verified the mathematical model of the controller has been done in MATLAB Simulink.

From the simulation results the prime controller has been chosen by comparing the criteria of the response such as settling time, rise time, percentage of overshoot and steady state error. The Neural Network NARMA L2 controller is founded to give finest performance for Shell and Heat exchanger problem like temperature control. Later Need to compare Conventional PID and Advance Artificial Neural Network NARMA L2 Controller results which lead to decide which one is best for Chosen has a better performance than other.

**Keywords**— Artificial neural network NARMA L2 controller, PID controller, Shell and tube heat exchanger, MATLAB–Simulink.

## I. INTRODUCTION

The Shell and Tube Heat exchanger system is widely used in chemical plants, many process industries such as petro chemical industries, paper making industries and water treatment industries because it can sustain wide range of temperature [1,3]. The main purpose of a STH system is to transfer heat from a hot fluid to a cold fluid, so the temperature control of outlet fluid is prime importance. The best way to learn about control systems is to design a controller, apply it to the system and then observe the system in operation. One example of systems that use control theory is shell and tube heat exchanger. The transfer

of heat is one of the most basic unit operations in the process industries. The control problem of heat exchanger is rather difficult due to its nonlinear dynamics and particularly to the variable steady state gain and the time constant with the flow rate of the process [2,4].

From simulation studies compared the dynamic behavior of a ST HE using different control strategies, such as conventional PID controller and Neural network controller (NARMA – L2) to control the outlet cold water temperature. A step change is given in the hot water inlet flow rate which is considered as a manipulated variable [5,8,9]. The performance show that the NARMA-L2 Controller achieves finest performance than the PID controller for servo and regulatory problems. The performance criteria used for different control modes are controller gave better performance as well as the parameters of the step changes of the system such as overshoot value, settling time and rise time [6,7].

## II. MATHEMATICAL MODELING OF SHELL AND TUBE HEAT EXCHANGER

Process Identification by using heat exchanger; heating a cold fluid from 30°C to 50°C, 30°C to 60°C and 30°C to 70°C. Dynamic modeling of shell and tube heat exchanger based on physical parameters,

The energy balance can now be written as,

$q_c = U_c A_c (T_{ho} - T_{co})$ --- (1)	$q_h = U_h A_h (T_{co} - T_{ho})$ --- (3)
$\rho_c V_c C_{pc} \frac{dT_{co}}{dt} = \dot{m}_c C_{pc} (T_{ci} - T_{co}) + q_c$ --- (2)	$\rho_h V_h C_{ph} \frac{dT_{ho}}{dt} = \dot{m}_h C_{ph} (T_{hi} - T_{ho}) + q_h$ --- (4)

$\rho = \frac{Kg}{m^3}$	995.2	$\rho = \frac{Kg}{m^3}$	830
$h_i = \frac{W}{m^2 \cdot ^\circ C}$	6982	$h_s = \frac{W}{m^2 \cdot ^\circ C}$	1967
Total tube area m <sup>2</sup>	0.0756	Area for flow(m <sup>2</sup> )	0.00887

Where,

- $T_{ci} = 30$  are inlet initial steady state cold and hot fluid temperature ( $^{\circ}\text{C}$ ) respectively.
- $T_{co} = 50$  Required outlet temperature of cold fluid
- $V_c = 0.01$  volume of cold fluid ( $\text{m}^3$ )
- $V_h = 0.1$  are volume cold and hot fluid ( $\text{m}^3$ )
- $\dot{m} = A\rho v = 0.007$  Mass flow rate of cold fluid ( $\frac{\text{Kg}}{\text{sec}}$ ).
- $\dot{m} = A\rho v = 6.25$  Mass flow rate of hot fluid ( $\frac{\text{Kg}}{\text{sec}}$ ).

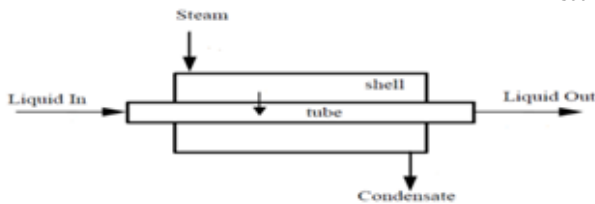

Fig.1: Schematic diagram of Shell-and-tube heat exchanger.

### III. DESIGN OF PID CONTROLLER

The PID control scheme is named after its three correcting terms, whose sum constitutes the manipulated variable (MV). The proportional, integral, and derivative terms are summed to calculate the output of the PID controller.

Defining  $u(t)$  as the controller output, the final form of the PID algorithm is:

$$u(t) = MV(t) = K_p e(t) + K_i \int_0^t e(\tau) d\tau + K_d \frac{d}{dt} e(t)$$

Where,

$K_p$ : Proportional gain, a tuning parameter

$K_i$ : Integral gain, a tuning parameter

$K_d$ : Derivative gain, a tuning parameter

$e$ : Error =  $SP - PV$

$t$ : Time or instantaneous time (the present)

$T$ : Variable of integration; takes on values from time 0 to the present  $t$ .

3.1 The simulation study was carried out as shown in below Fig. 2. MATLAB - Simulink for PID control system

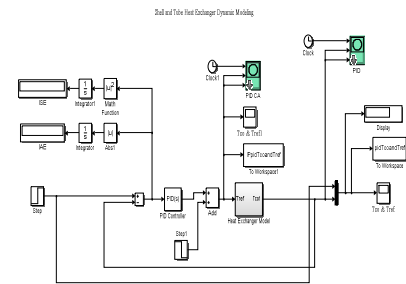

Fig.2: Block diagram of shell and tube heat exchanger system using PID Controller

### IV. NEURAL NETWORK NARMA L2 CONTROLLER

Neural network is a machine that is designed to model the way in which the brain performs a particular task or function of interest. The network is usually implemented by using electronic components or is simulated in software on a digital computer. To achieve good performance, neural networks employ a massive interconnection of simple computing cells referred to as neurons or processing units. A neural network is a massively parallel distributed processor made up of simple processing units.

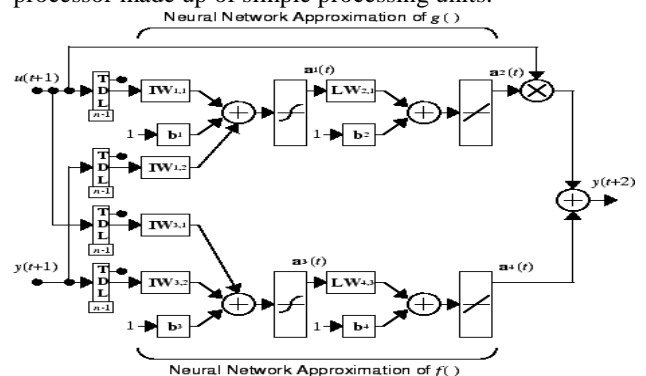

Fig.3: Neural Network NARMA L2 controller approximation.

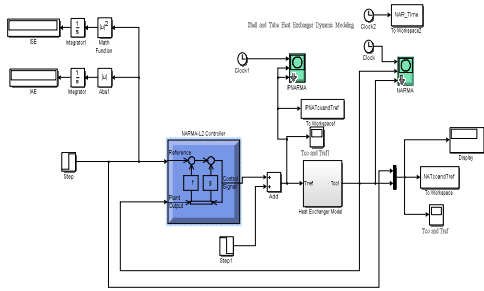

Fig.4:Block diagram of shell and tube heat exchanger system using neural network NARMA L2 Controller

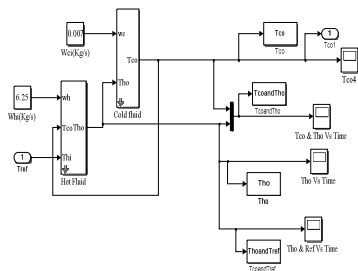

Fig.5:Sub System Of Shell And Tube Heat Exchanger

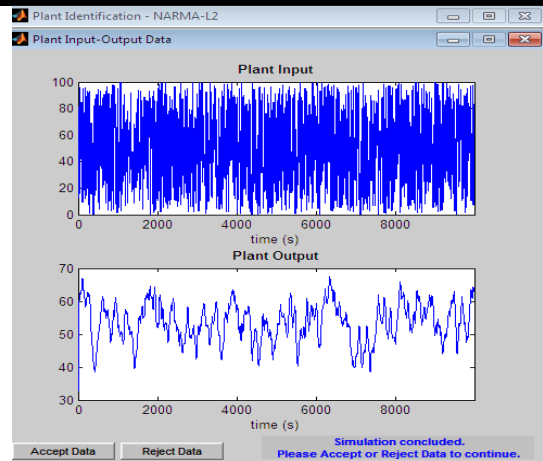

Fig. 7:Plant input and output data of NN NARMA L2 controller

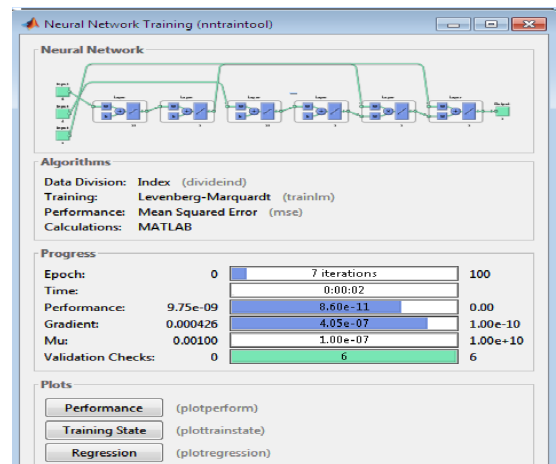

Fig.8:Neural network training data of NARMA L2 controller

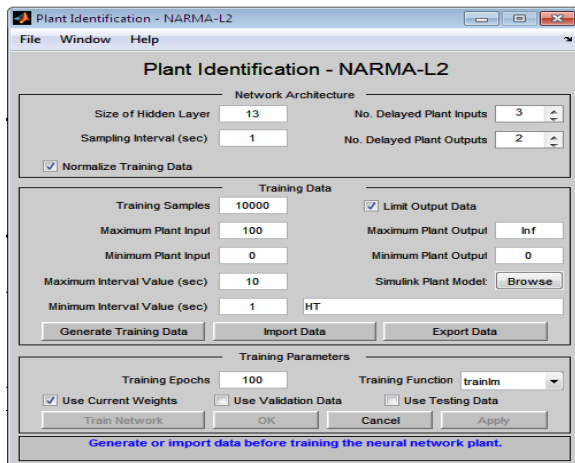

Fig. 6: Plant identification of NN NARMA L2 controller for shell and tube heat exchanger.

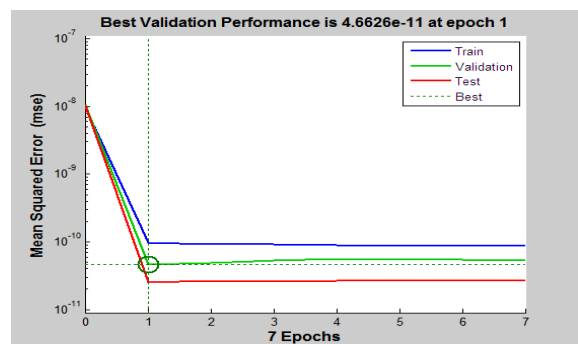

Fig.9:Training NARMA L2 using MAT LAB

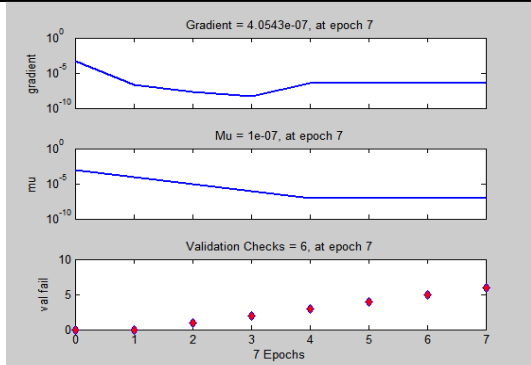

Fig.10: Validation data of NN NARMA L2 controller

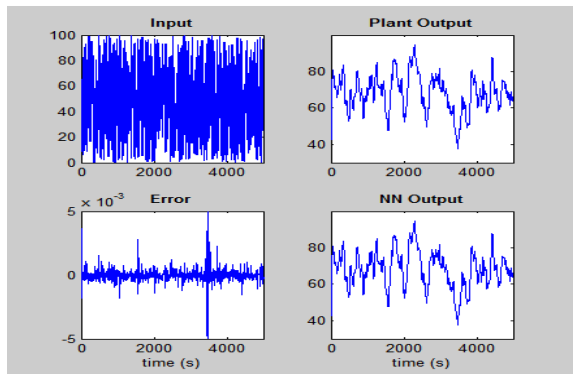
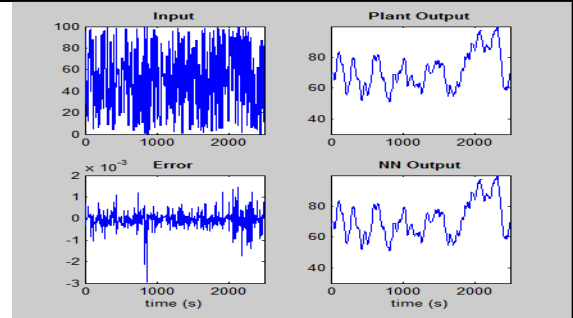

Fig.14: Testing data for NNNARMA L2 controller.

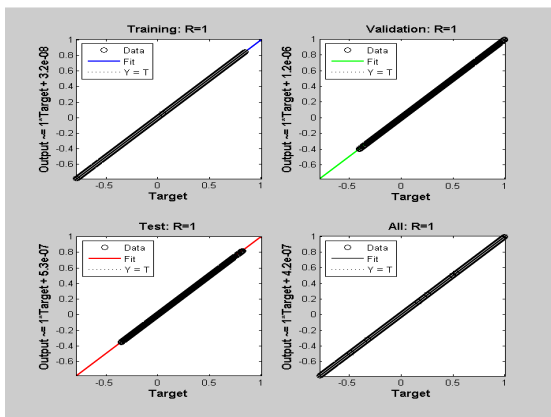

Fig.11: Regrisionflots of NN NARMA L2 controller

## V. RESULTS AND DISCUSSIONS

### 5.1 Simulation Results

In the simulation we choose different set points 30-50, 30-60 and 30-70 in °C w.r.t time(sec) both servo and regulatory problems. For regulatory problem +10% disturbance was given, The NARMA L2 controller reach set point and steady state without oscillations and low overshoot. The tracking of the set pointchange in a NARMA L2 is good compared with the PID Controller. Neural Network NARMA L2 has less error than PID controller and hence Neural Network NARMA L2 shows finest performance than PID controller results are Shown in Fig,15 to Fig,20.

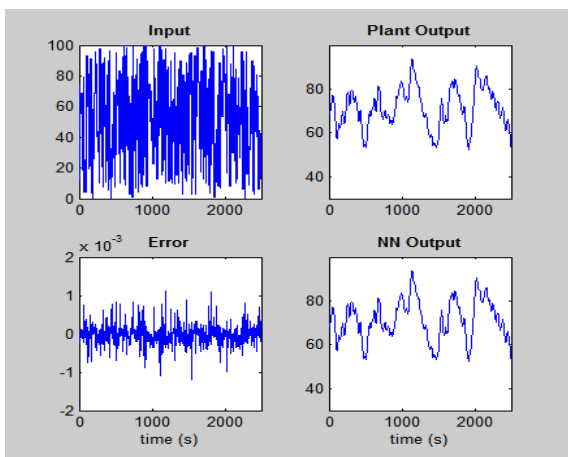

Fig.12: Validation data for NNNARMA L2 controller

Fig.13: Training data for NNNARMA L2 controller

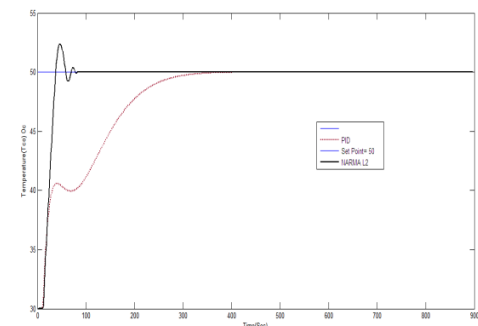

Fig.15: Servo Response of PID and neural network NARMA L2 Controller Output TCo (0c) Vs Time (sec), SP=30-50.

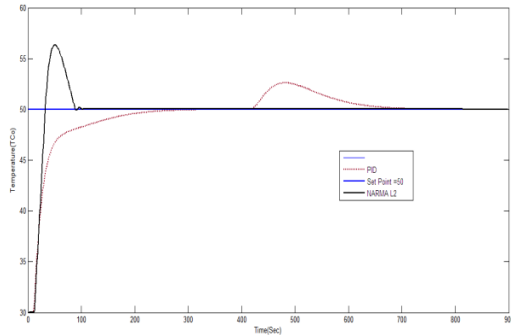

Fig.16: regulatory Response of PID and neural network NARMA L2 Controller Output TCo (0c) Vs Time (sec), (+10%), SP=30-50.

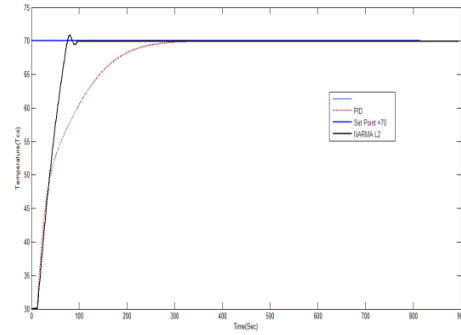

Fig.19: Servo Response of PID and neural network NARMA L2 Controller Output TCo (0c) Vs Time (sec), SP=30-70.

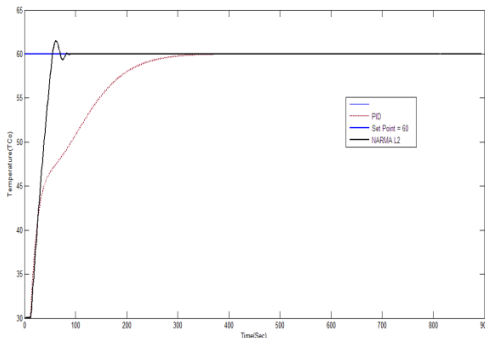

Fig.17: Servo Response of PID and neural network NARMA L2 Controller Output TCo (0c) Vs Time (sec), SP=30-60.

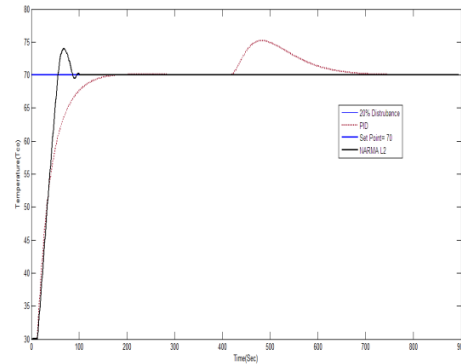

Fig.20: regulatory Response of PID and neural network NARMA L2 Controller Output TCo (0c) Vs Time (sec), (+10%) SP=30-70

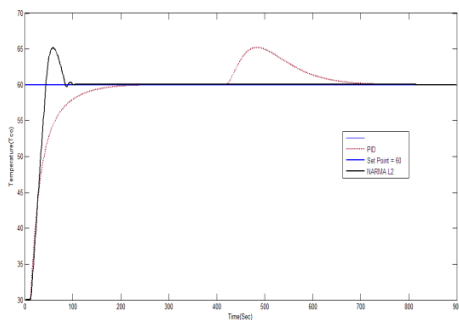

Fig.18: regulatory Response of PID and neural network NARMA L2 Controller Output TCo (0c) Vs Time (sec), (+10%) SP=30-60.

## VI. CONCLUSION

The dynamic Shell and Tube Heat Exchanger model presented in this report is the first step in the development of a dynamic heat exchanger model that can give cold fluid outlet temperature prediction for simultaneously varying exchanger hot fluid inlet temperature conditions expected under action of a controller. For Shell and Tube heat exchanger, the performance of NARMA-L2 controller is found to be superior than that of the conventional PID controller and for regulatory problem NARMA L2 no disturbance was occurred. To efficiently control the temperature, designed two kinds of controllers and the modeling of heat exchanger is done using neural network, it can be concluded that the shell and tube heat exchanger model using successful and has very good accuracy results. It is observed that NARMA L2 controller gives a much better response than conventional PID controller.

#### ACKNOWLEDGEMENTS

The authors would like to thank TEQIP-II Co-Ordinator, University College of Technology, Osmania University.

#### REFERENCE

- [1] Chidamabaram, M., and Malleswararao, Y.S.N., 1992. Non-linear controllers for a heat exchanger, J. Proc. Contr., 2(1), 17 - 21 .
- [2] Riverol, C., and Naplitano, V., "Use of Neural Networks as a Tuning Method for an Adaptive PID Application in a Heat Exchanger", Transactions Institution of Chemical Engineers, Vol.78, Part A, November, 2000.
- [3] Diaz, G. C., "Simulation and Control of Heat Exchangers Using Artificial Neural Networks", PhD Thesis, Aerospace and Mechanical Engineering, University of Notre Dame, March, 2000.
- [4] Diaz, G., Sen, M., Yang, K. T., and McClain, R. L., "Dynamic Prediction and Control of Heat Exchangers Using Artificial Neural Networks", International Journal of Heat and Mass Transfer, Vol.44, PP.1671-1679, 2001.
- [5] Henriques, J., Gil, P., Cardoso, A., and Dourado, A., "Scheduling of PID Controllers by Means of a Neural Network with Application to a Solar Power Plant", The World's Largest Professional Association for the Advancement of Technology, IEEE, 2002.
- [6] Mandavgane, S. A., and Pandharipande, S. L., "Application of Optimum ANN Architecture for Heat Exchanger Modeling", Indian Journal of Chemical Technology, Vol.13, PP.634-639, November, 2006
- [7] Y. Zhao, S. Zhou, and Li Li, "Dynamic Characteristics Modeling of a Heat Exchanger Using Neural Network", Proc. First International Conference on Intelligent Networks and Intelligent Systems, pp. 13-18, 1-3 November 2008.
- [8] Vasickaninova, A., Bakosova, M., Meszaros, A., and Klemes, J., "Neural Network Predictive Control of a Heat Exchanger", Chemical Engineering Transactions, Vol.21, 2010.
- [9] Dirman Hanafi and Mohd Nor, "Heat Exchanger's Shell and Tube Modeling for Intelligent Control Design", Department of Mechatronic and Robotic Engineering, Faculty of Electrical and Electronic Engineering. International Conference on Computer and Communication Devices (ICCCD 2011). Vol. 2