

A Review on Power Quality Improvement via Custom Power Devices

N.D.Mehta, Ashish P. Patel, A. M. Haque

Assistant Professor, Vishwakarma Government Engineering college , Chandkheda, Gujarat, India

Abstract— Power Quality has been said a set of electrical boundaries of the electrical supply provided under normal operating condition that allow equipment to function in its rated condition without significant loss of performance and life expectancy that do not disturb or disrupt the consumers' process. Performance degradation results when the electrical power supplied to equipment is deficient. Thus power quality improvement is the main concern of present era. The problems of power quality are rising exponentially from the last few decades due to the rising demand for power and the need for their improvement is indeed a big question. The main power quality problems such as voltage sags and swells, power interruptions (short and long), voltage spike, harmonic distortion, noise have led to financial losses. To avoid huge losses and to overcome the above mentioned problems, power electronics has evolved with its new types of devices known as Custom Power Devices which are being reviewed in this paper.

Keywords— Power Quality, Custom Power Devices, Voltage Sags, Power Electronics.

I. INTRODUCTION

Power Quality is the main concern of the present era. Power quality describes the variation in the voltage, frequency and current in the power system. Enlargement in the power system during the last few decades have introduced more no of equipment which are not so tolerant towards these variations. The sophistication of electrical appliances with the development of electronics has added to the demand of quality power at the consumer premises.[1]

Electrical devices are becoming smaller and more sensitive to power quality aberrations due to the proliferation of electronics.[2] Challenging environment has been developed for power producers for the quality of power. Thus an open and competitive market has paved its way. Deregulation in the market is the result of such a scenario. The deregulation of electric power energy has boosted the public awareness toward power quality among the different categories of users [3]. The impact of power quality problem is increasingly felt by the customers-industrial, commercial and the residential. This paper

reviews the custom power devices which are used for the mitigation of power quality problems.

II. POWER QUALITY PROBLEMS

Power Quality problems encompass a wide range of disturbances such as voltage sags/swells, flicker, harmonics distortion, impulse transient, and interruptions.

Voltage dip: A voltage dip is used to refer to short-term reduction in voltage of less than half a second.

Voltage sag: Voltage sags can occur at any instant of time, with amplitudes ranging from 10–90% and a duration lasting for half a cycle to one minute.

Voltage swell: Voltage swell is defined as an increase in rms voltage or current at the power frequency for durations from 0.5 cycles to 1 min.

Voltage 'spikes', 'impulses' or 'surges': These are terms used to describe abrupt, very brief increases in voltage value.

Voltage transients: They are temporary, undesirable voltages that appear on the power supply line. Transients are high over-voltage disturbances (up to 20KV) that last for a very short time.

Harmonics: The fundamental frequency of the AC electric power distribution system is 50 Hz. A harmonic frequency is any sinusoidal frequency, which is a multiple of the fundamental frequency. Harmonic frequencies can be even or odd multiples of the sinusoidal fundamental frequency.

Flickers: Visual irritation and introduction of many harmonic components in the supply power and their associated ill effects.

2.1 Causes of Dips, Sags and Surges

1. Rural location remote from power source
2. Unbalanced load on a three phase system
3. Switching of heavy loads
4. Long distance from a distribution transformer with interposed loads
5. Unreliable grid systems
6. Equipment not suitable for local supply

2.2 Causes of Transients and Spikes

1. Lightning
2. Arc

welding

3. Switching on heavy or reactive equipment such as motors, transformers, motor drives

4. Electric grade switching

III. STANDARDS FOR POWER QUALITY

3.1 IEEE Standard

The Technical Committees of the IEEE societies and the Standards Coordinating Committees of IEEE Standards Board develop IEEE standards. The IEEE standards associated with voltage sags are given below. IEEE 446-1995, "IEEE recommended practice for emergency and standby power systems for industrial and commercial applications range of sensibility loads". The standard discusses the effect of voltage sags on sensitive equipment, motor starting, etc. It shows principles and examples on how systems shall be designed to avoid voltage sags and other power quality problems when backup system operates.

IEEE 493-1990, "Recommended practice for the design of reliable industrial and commercial power systems"

The standard proposes different techniques to predict voltage sag characteristics, magnitude, duration and frequency. There are mainly three areas of interest for voltage sags. The different areas can be summarized as follows:

(A) Calculating voltage sag magnitude by calculating voltage drop at critical load with knowledge of the network impedance, fault impedance and location of fault.

(B) By studying protection equipment and fault clearing time it is possible to estimate the duration of the voltage sag.

(C) Based on reliable data for the neighborhood and knowledge of the system Parameters an estimation of frequency of occurrence can be made.

IEEE 1100-1999, "IEEE recommended practice for powering and grounding Electronic Equipment" This standard presents different monitoring criteria for voltage sags and has a chapter explaining the basics of voltage sags. It also explains the background and application of the CBEMA (ITI) curves. It is in some parts very similar to Std. 1159 but not as specific in defining different types of disturbances.

IEEE 1159-1995, "IEEE recommended practice for monitoring electric power quality" The purpose of this standard is to describe how to interpret and monitor electromagnetic phenomena properly. It provides unique definitions for each type of disturbance IEEE 1250-1995, "IEEE guide for service to equipment sensitive to momentary voltage disturbances"

3.2 SEMI International Standards

The SEMI International Standards Program is a service

Due to a problem of voltage sag manufacturers and the buyers use these standards to meet better power quality requirements. Manufactures develop products meeting the requirements of a standard, and buyers demand from the manufactures that the product comply with the standard. The most common standards dealing with power quality are the ones issued by IEEE, IEC, CBEMA, and SEMI.

offered by Semiconductor Equipment and Materials International (SEMI). Its purpose is to provide the semiconductor and flat panel display industries with standards and recommendations to improve productivity and business. SEMI standards are written documents in the form of specifications, guides, test methods, terminology, and practices. The standards are voluntary technical agreements between equipment manufacturer and end-user. The standards ensure compatibility and interoperability of goods and services. Considering voltage sags, two standards address the problem for the equipment. SEMIF47-0200 "Specification for semiconductor processing equipment voltage sag immunity". The standard addresses specifications for semiconductor processing equipment voltage sag immunity. It only specifies voltage sags with duration from 50ms up to 1s. SEMI F42-0999, "Test method for semiconductor processing equipment voltage sag immunity" This standard defines a test methodology used to determine the susceptibility of semiconductor processing equipment and how to qualify it against the specifications.

IV. CUSTOM POWER DEVICES

To overcome the above mentioned problems various measures have been taken which are the uses of lossless passive filters, active power filters and hybrid active power filters but due to their disadvantages these are discarded. So new type of devices known as the customer power devices are coined. Custom Power (CP) pertains to the use of power electronic controllers for power distribution systems [4].

The Custom Power term was proposed to designate a new generation of semiconductor devices based on power electronics, designed to operate at medium and low voltage levels. The custom power devices enhance the quality and reliability of power that is delivered to customers and also improve the service quality of distribution network. They can present faster responses and a more accurate setting in basic and important functions such as voltage regulation, reactive power compensation, reduction in the rate of harmonic distortion, or the limitation of short circuit currents. [2]. The custom power devices are mainly divided into two groups: network reconfiguring type and compensating type.

The complete classification of custom power devices is shown in the Fig 1.

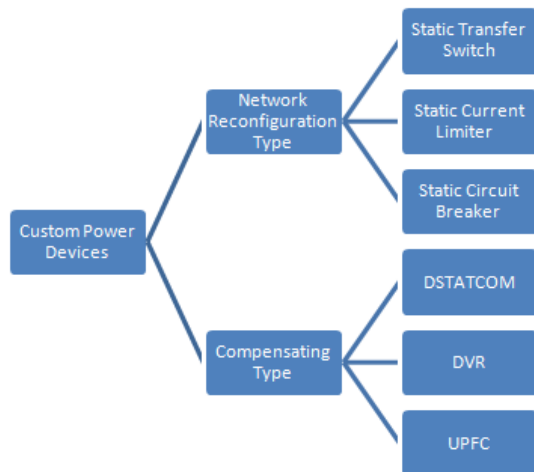

Fig.1: Configuration of custom power devices

Custom power is the concept of employing power electronics based controllers in 1 KV through 32 KV distribution systems for supplying a compatible level of power quality necessary for adequate performance of selected facilities and process.

V. NETWORK RECONFIGURING TYPE CUSTOM POWER DEVICES

These devices are series-connected devices. A. Ghosh and G. Ledwich have described that network reconfiguring type equipment are gate turn-off (GTO) based or thyristor based switches [4]. Network reconfiguring devices include static current limiter (SCL), static circuit breaker (SCB) and static transfer switch (STS).

However, most popular network reconfiguring device is STS. The solid state transfer switch or static source transfer switch (STS) uses solid-state switches to provide an almost seamless load transfer to an alternate feeder/source to protect a sensitive load from momentary interruptions and voltage sag/swell or fault in the supplying feeder. The transfer time can be as low as quarter of the rated frequency cycle [5].

A. Static Transfer Switch System

The static transfer switch is a device between the AC mains and the inverter to provide uninterruptible AC power. After an extremely quick detection of a mains fault (sag or interruption), the static switch transfers the load almost without cut off to the healthy AC line. The STS provides 20 times faster load transfer (typically $\frac{1}{4}$ of a cycle), compared to conventional automatic transfer switches (ATS), which ensures the uninterrupted operation of even the most sensitive electronic equipment [8].

When there is a sag or an interruption on the AC mains feeder, the switches on the auxiliary feeder turn on immediately and that on the main feeder turn off at the

first natural current zero, i.e. transferring loads to the healthy feeder. Hence STS provides a seamless transfer of electrical energy between the two feeders. Note that the STS cannot protect against sags originating in the transmission system, which will also affect the alternative supply [7].

The STS system consists of three main components, as shown in Fig.

1. The static transfer switch STS, consists of two three-phase ac thyristor switches connected back to back (anti-parallel), directing power from two independent feeders to the load.

2. The mechanical bypass switch MTS, operates as a standard mechanical transfer switch when the static transfer switch is out of service.

3. Isolating switches and Control, during normal condition, the switch connected to the primary feeder is kept closed and the switch on the secondary feeder is kept opened[8].

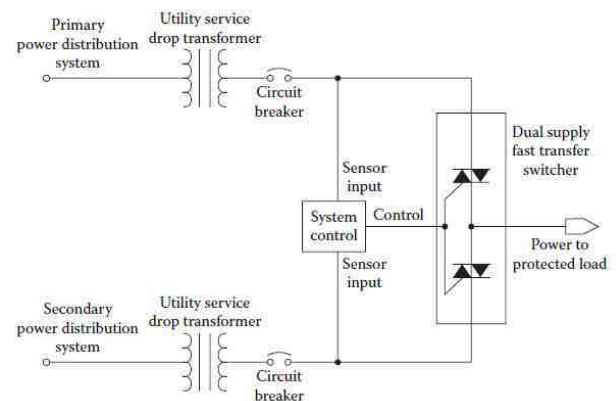

Fig.2: Static transfer Switch

Disadvantages

1. One disadvantage is that there should be a secondary feeder, independent from the main source (e.g. a feeder to another substation), must be available.
2. The transfer time increases even more in case of regenerative load, e.g. induction motors [9].
3. A thyristor, which is the basis of the solid-state transfer switch, is not a pure conductor and this raises some issues in terms of losses and cooling. As a result, relatively large cooling equipment is required, which imposes additional operating costs on the user to maintain proper cooling. It also results in reduced efficiency and lower reliability in the device [10]

B. Static Current Limiter

Static current limiter is a custom power device applied for high fault current limiting. It offers high impedance during fault condition and low impedance during normal condition.

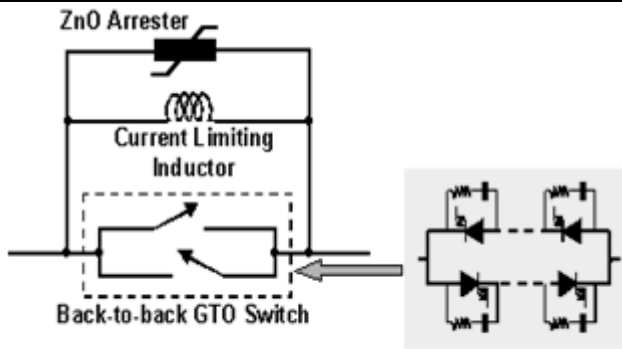

Fig.3: Static Current Limiter

These are of two types-

- GTO-Switched
- Thyristor- Controlled

In GTO based static current limiter, current limiting impedance is shunted across a pair of anti-parallel GTO switches during the fault. As soon as the fault is detected it comes in series with a faulty circuit and large fault is interrupted by turning off the GTO switch [6].

Disadvantage

- 1) Sudden interruption of large current leads to high transient overvoltage and nuisance tripping of small PWM adjustable-speed-drives [12].
- 2) Also, these transient oscillations excite LC circuits formed by the customer step down transformers and the low-voltage PFC capacitors at the customer side. This gives rise to voltage magnification at the customer side [13].

Thyristor-Controlled SCL utilizes thyristor to incorporate limiting impedance to the system as soon as fault occurs. In comparison to GTO switched SCL, the switches of thyristor based SCL turn on during fault. In this way, transient oscillations are avoided.

These are of two types.

- 1) Thyristor controlled series capacitors (TCSCs)
- 2) Thyristor Controlled series reactors (TCSR)[6].

A. Static Circuit Breaker

Static circuit breaker breaks a faulted circuit much faster than a mechanical circuit breaker. It is a high-speed switching device, applied to reduces the electrical fault and protect from large current in distribution system.

It employed GTO or thyristor switching technology. The static circuit breaker offers a very long life, higher reliability and complete safety due to complete isolation from mains. The circuit offers very high speed sensitivity which ensures safety from electric flash as well as short circuit. A typical static circuit breaker will

switch in a matter of microseconds, as opposed to milliseconds or even seconds for a mechanical version [14].

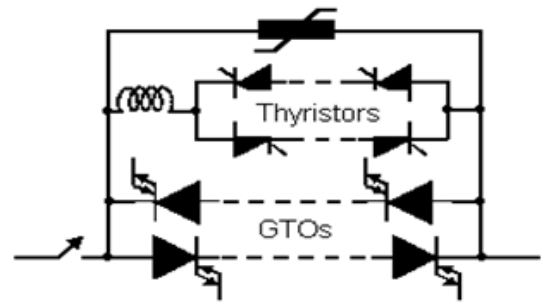

Fig.4: Static Circuit Breaker

Disadvantages

- 1) The main disadvantage of the SCB is the higher cost and complexity in design.
- 2) Other major drawback in SCB is on-state losses. [15]

VI. COMPENSATING POWER DEVICES

The compensating custom power devices are used for active filtering, load balancing, power factor improvement voltage regulating(sag/ swell). These devices are mainly three types: static shunt compensator, series and hybrid compensator. These are also called as DSTATCOM, DVR and UPFC respectively.

A. Dynamic Voltage Restorer (DVR)

Dynamic voltage restorer (DVR) can provide the cost effective solution to mitigate voltage sag by establishing the appropriate voltage quality level, required by the customer [17, 18]. It is recently being used as the active solution for voltage sag mitigation. The basic structure of a DVR is shown in Fig.4. It is divided into six categories:

- (i) *Energy Storage Unit*: It is responsible for energy storage in DC form. Flywheels, batteries, superconducting magnetic energy storage (SMES) and super capacitors can be used as energy storage devices. It supplies the real power requirements of the system when DVR is used for compensation [18].
- (ii) *Capacitor*: DVR has a large DC capacitor to ensure stiff DC voltage input to inverter.
- (iii) *Inverter*: An Inverter system is used to convert dc storage into ac form [17]. Voltage source inverter (VSI) of low voltage and high current with step up injection transformer is used for this purpose in the DVR Compensation technique [18].
- (iv) *Passive Filters*: Filters are used to convert the inverted PWM waveform into a sinusoidal waveform. This is achieved by eliminating the unwanted harmonic components generated VSI action. Higher orders harmonic components distort the compensated output voltage [17].

(v) *By-Pass Switch*: It is used to protect the inverter from high currents in the presence of faulty conditions. In the event of a fault or a short circuit on downstream, the DVR changes into the bypass condition where the VSI inverter is protected against over current flowing through the power semiconductor switches. The rating of the DVR inverters becomes a limiting factor for normal load current seen in the primary winding and reflected to the secondary winding of the series insertion transformer. For line currents exceeding the rating, a bypass scheme is incorporated to protect the power electronics devices [20].

(vi) *Voltage Injection Transformers*: In a three-phase system, either three single-phase transformer units or one three phase transformer unit can be used for voltage injection purpose. [16].

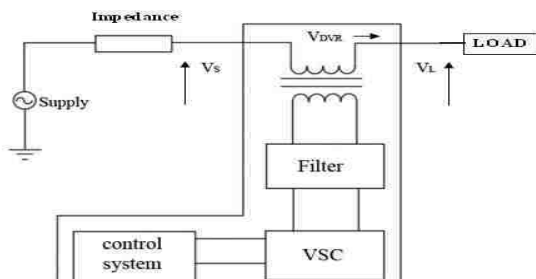

Fig: 5: Schematic Diagram of DVR

Basic principal of DVR is to transfer the voltage sag compensation value from DC side of the inverter to the injected transformer after filter. The compensation capacity of a particular DVR depends on the maximum voltage injection capability and the active power that can be supplied by the DVR. When DVR's voltage disturbance occurs, active power or energy should be injected from DVR to the distribution system [21]. A DC system, which is connected to the inverter input, contains a large capacitor for storage energy. It provides reactive power to the load during faulty conditions. When the energy is drawn from the energy storage capacitors, the capacitor terminal voltage decrease. Therefore, there is a minimum voltage required below which the inverter of the DVR cannot generate the require voltage thus, size and rating of capacitor is very important for DVR power circuit [22]. The DC capacitor value for a three phase system can be derived [23]. The most important advantage of these capacitors is the capability to supply high current pulses repeatedly for hundreds of thousands of cycles. Selection of capacitor rating is discussed on the basis of RMS value of a capacitor current, rated voltage of a capacitor and VA rating of the capacitor [24].

Advantage

1. DVR are a class of custom power devices for

providing reliable distribution power quality.

2. DVR suppresses voltage sags and swells compensation it can also added other features like: line voltage harmonics compensation, reduction of transients in voltage and fault current limitations.

Disadvantage

1. High speed transients cannot be compensated.
2. Some sags are not corrected within the limited time frame of mechanical switching devices.
3. Transformer taps may be used, but tap changing under load is costly.

Application

1. Voltage sag and swell protection
2. Voltage balancing
3. Voltage regulation
4. Flicker attenuation

B. Distribution Static Compensator (DSTATCOM)

DSTATCOM [26, 28] is to suppress voltage variation and control reactive power in phase with system voltage. It can compensate for inductive and capacitive currents linearly and continuously. The terminal voltage (V_{bus}) is equal to the sum of the inverter voltage (V_{vsc}) and the voltage across the coupling transformer rective V_L in both capacitive and inductive modes. I mean that if output voltage of DSTATCOM (V_{vsc}) is in phase with bus terminal voltage (V_{bus}) and V_{vsc} is greater than V_{bus} , DSTATCOM provides reactive power to system. And if V_{vsc} is smaller than V_{bus} , DSTATCOM absorbs reactive power from power system. Bus and V_{vsc} have the same phase, but actually they have a little phase difference to component the loss of transformer winding and inverter switching [26], so absorbs some real power from system. The active power is transferred from the AC terminal to the DC capacitor and causes the DC link voltage to rise. The active and reactive power may be expressed by the following equations: [30]

$$p = \left(\frac{V_{bus} * V_{vsc}}{X_L} \right) \sin \delta$$

$$Q = \frac{V_{2bus}}{x_l} - \frac{V_{bus} * V_{vsc}}{x_l} * \cos \delta$$

In any practical DSTATCOM there are losses in the transformer windings and in the converter switches. These losses consume active power from the AC terminals. Accordingly, a small phase difference always exists between the VSC voltage and the AC system voltage. A summary of the power exchanges between the DSTATCOM and the AC system as a function of the DSTATCOM output voltage V_{vsc} and the AC system voltage V_{bus} .

Advantage

1. The response is much faster to changing system conditions.
2. It does not contribute to short circuit current.
3. It has a symmetric lead-lag capability.
4. It has no moving parts and hence the maintenance is easier.
5. It has no problems of loss of synchronism under a major disturbance.

Disadvantage

1. It has a high cost level due to complex system setup.

Application

1. Power factor improvement
2. Current Harmonic compensation
3. Load current balancing
4. Flicker effect compensation

C. Unified Power Flow Compensator (UPFC)

The UPFC [27-29] is the most versatile and complex of the FACTS devices, combining the features of the STATCOM and the SSSC. The UPFC can provide simultaneous control of all basic power system parameters, viz., transmission voltage, impedance and phase angle. It is recognized as the most sophisticated power flow controller currently, and probably the most expensive one. The basic components of the UPFC are two voltage source inverters (VSI's) sharing a common dc storage capacitor, and connected to the power system through coupling transformers. One VSI is connected in shunt to the transmission system via a shunt transformer, while the other one is connected in series through a series transformer. A basic UPFC functional scheme is shown in fig.5 The series inverter is controlled to inject a symmetrical three phase voltage system (V_s), of controllable magnitude and phase angle in series with the line to control active and reactive power flows on the transmission line. So, this inverter will exchange active and reactive power with the line. The reactive power is electronically provided by the series inverter, and the active power is transmitted to the dc terminals. The shunt inverter is operated in such a way as to demand this dc terminal power (positive or negative) from the line keeping the voltage across the storage capacitor V_{dc} constant. So, the net real power absorbed from the line by the UPFC is equal only to the losses of the inverters and their transformers. The remaining capacity of the shunt inverter can be used to exchange reactive power with the line so to

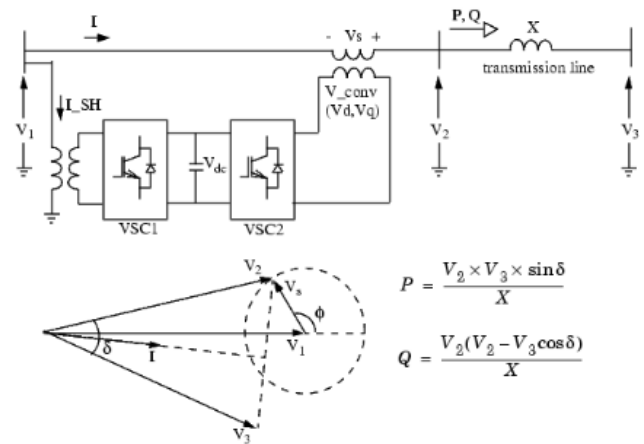

Fig.6: Block Diagram of UPFC

provide a voltage regulation at the connection point. The two VSI's can work independently of each other by separating the dc side. So in that case, the shunt inverter is operating as a STATCOM that generates or absorbs reactive power to regulate the voltage magnitude at the connection point. Instead, the series inverter is operating as SSSC that generates or absorbs reactive power to regulate the current flow, and hence the power flow on the transmission line. The UPFC has many possible operating modes. In particular, the shunt inverter is operating in such a way to inject a controllable current, into the transmission line. The shunt inverter can be controlled in two different modes:

VAR Control Mode: The reference input is an inductive or capacitive VAR request. The shunt inverter control translates the var reference into a corresponding shunt current request and adjusts gating of the inverter to establish the desired current. For this mode of control a feedback signal representing the dc bus voltage, V_{dc} , is also required.

Automatic Voltage Control Mode: The shunt inverter reactive current is automatically regulated to maintain the transmission line voltage at the point of connection to a reference value. For this mode of control, voltage feedback signals are obtained from the sending end bus feeding the shunt coupling transformer. The series inverter controls the magnitude and angle of the voltage injected in series with the line to influence the power flow on the line. The actual value of the injected voltage can be obtained in several ways.

Direct Voltage Injection Mode: The reference inputs are directly the magnitude and phase angle of the series voltage. **Phase Angle Shifter Emulation mode:** The reference input is phase displacement between the sending end voltage and the receiving end voltage.

Line Impedance Emulation mode: The reference input is an impedance value to insert in series with the line impedance. **Automatic Power Flow Control Mode:** The

reference inputs are values of P and Q to maintain on the transmission line despite system changes.

Advantage

- 1.Has the unique capability to provide independent and concurrent control for the real and reactive line power flow, as well as for the regulation of the bus voltage.
2. Has a flexible circuit structure to be reconfigured for independent shunt (STATCOM) and series (SSSC) compensation, as well as for only shunt or only series compensation at double rating.
- 3.Has a rugged and reliable GTO-based converter structure that is capable of operating properly in utility environment.

Disadvantage

- 1.It has a high cost level due to complex system setup.

Application

- 1.Voltage sag and swell correction
- 2.Voltage balancing
- 3.Voltage regulation
- 4.Flicker attenuation
- 5.VAR compensation
- 6.Harmonic suppression
- 7.Current balancing
- 8.Active and reactive power control

VII. CONCLUSION

This paper provides a literature review of the custom power devices. The advantages and disadvantages of the devices are clearly mentioned. These are the devices which successfully mitigate the power quality problems like voltage sag and swell, voltage transients harmonics and flickers. The various standards are also clearly mentioned for the Power Quality. DVR is a custom power device which provides reliable distribution power quality. DVR suppresses voltage sags and swells compensation it can also add other features like: line voltage harmonics compensation, reduction of transients in voltage and fault current limitations. It was observed that its capacity for power compensation and voltage regulation depends mainly on two factors: the rating of the dc storage device and the characteristics of the coupling transformer. These two factors determine the maximum value of sag mitigation that the DVR can provide. The SSTS proved to be a suitable device for screening selected load points against faulted conditions, but it does require an alternative feeder being available. The transfer of load from a faulted feeder to a healthy one can be achieved in a short period of time. The DSTATCOM response is much faster to changing system condition. The UPFC has the unique capability to provide independent and concurrent control

for the real and reactive line power flow, as well as for the regulation of the bus voltage but has the high cost level due to system setup.

Custom Power Devices	Applications
Static S hunt Compensator (D -STATCOM)	Power factor improvement Current Harmonic compensation Load current balancing Flicker effect compensation
Static Series Compensator (DVR)	Voltage sag and swell protection Voltage balancing Voltage regulation Flicker attenuation
Unified Power Quality Compensator (UPQC)	Voltage sag and swell correction Voltage balancing Voltage regulation Flicker attenuation VAR compensation Harmonic suppression Current balancing Active and reactive power control
Static transfer switch (STS)	Voltage sag and swell protection
Solid state breaker	Fault current protection and limitation

REFERENCES

- [1] A. Ghosh And G. Ledwich, Power Quality Enhancement Using Custom Power Devices, Kluwer Academic Publishers, The Netherlands, 2002
- [2] S. Nilsson, "Special Application Considerations For Custom Power Sys- Tems," In Proc. Ieee Power Eng. Soc., Winter Meeting 1999 , Vol. 2, 1999, Pp. 1127-1130.
- [3] A. M. Gole, O. B. Nayak, T. S. Sidhu, And M. S. Sachdev, "A Graphical Electromagnetic Simulation Laboratory For Power Systems Engineering Programs," IEEE Trans. Power Syst. , Vol. 11, Pp. 599-606, May 1996.
- [4] N. Mohan, T.M. Undeland, W.P. Robbins, Power Electronics Converters, Applications and Design, JohnWiley, New York, 1995.
- [5] A. Baggini, Handbook Of Power Quality, John Wiley And Sons, Ltd. West Sussex, England, 2008.
- [6] Engr. Aamirhanif (04-Uet/Phd-Ee-16), Power Flow Control Strategy At The Load Bus In The Presence Of Dispersed Generation, Department Of

- Electrical Engineering, University Of Engineering And Technology Taxila, Pakistan 2000
- [7] Jipping, J. And Carter, W., Application And Experience With A15 Kv Static Transfer Switch, IEEE Trans. Power Delivery, Vol. 14, No. 4, Oct. 1999, Pp. 1477-1481.
- [8] Mahmoud El-Gammal, Amr Abou-Ghazala And Tarek El- Shennawy, Custom Power Devices For Voltage Sags Mitigation: A Techno-Economic Analysis, (Electrical Review), Issn 0033-2097, R. 86 Nr 8/2010.
- [9] Sannino, A., Sts And Induction Motors, IEEE Industry applications Magazine, July 2003, Pp. 50-57.
- [10] John J. Paserba, Gregory F. Reed, Masatoshi Takeda And Tomohikoaritsuka, Facts And Custom Power Equipment For The Enhancement Of Power Transmission System Performance And Power Quality, Symposium Of Specialists In Electric Operational And Expansion Planning (Vii Sepope) Curitiba, Brazil, May 21-26, 2000.
- [11] Arindamghosh, Power Quality And Custom Power, Indian Institute Of Technology, Kanpur, India, July 2003.
- [12] M. M. Granaghan, T. Grebe, G. Hensley, T. Singh And M. Samotyj, "Impact Of utility Switched Capacitors On Customer Systems, Part Ii- Adjustable Speed Drive concerns," IEEE Transactions On Power Delivery, Vol. 6, No. 4, Pp. 1623-1628, 1991.
- [13] M. M. Granaghan, T. Grebe, G. Hensley, T. Singh And M. Samotyj, "Impact Of utility Switched Capacitors On Customer Systems, Part I- Adjustable Speed Drive concerns," IEEE Transactions On Power Delivery, Vol. 7, No. 2, Pp. 862-868, 1992.
- [14] Christoph Meyer, Student Member, IEEE, Stefan Schröder, Member, IEEE, And Rik W. De Doncker, Fellow, IEEE, Solid-State Circuit Breakers And Current Limiters For Medium-Voltage Systems Having Distributed Power Systems, IEEE Transactions On Power Electronics, Vol. 19, No. 5, September 2004.
- [15] Meyer C. And De Donker, Solid State Circuit Breaker Based On Active Thyristor Topologies, IEEE Transactions On Power Electronics, Vol. 21, Issue:2, March 2006.
- [16] Othmane Abdelkhalek, Abderrahmane Kechich, Tarek Benslimane, Chellali Benachaiba, Mohammed Haidas, "More Stability and Robustness with the Multi-loop Control Solution for Dynamic Voltage Restorer (DVR)" SERBIAN JOURNAL OF ELECTRICAL ENGINEERING Vol. 6, No. 1, May 2009, 75-88
- [17] C. Zhan, M. Barnes, V.K. Ramachandaramurthy, And N. Jenkis, "Dynamic Voltage Restorer With Battery Energy Storage For Voltage Dip Mitigation" Power Electronics And Variable Speed Drives, 18-19, Conference Publication No.475, IEEE September 2000.
- [18] Francisco Jurado, Manuel Valverde, And Jose Carpio, "Voltage Sag Correction By Dynamic Voltage Restorer Based On Fuzzy Logic Control" IEEE 2003.
- [19] Kasuni Perera, Daniel Salomon Son, Arulampaiam, Atputharajah, Sanath Alahakoon, "Automated Control Technique For A Single Phase Dynamic Voltage Restorer" IEEE, 2006.
- [20] S. V Ravi Kumar, S. Siva Nagaraju, "Simulation Of D- Statcom And Dvr In Power Systems" Arpn Journal Of Engineering And Applied Sciences Vol. 2, No. 3, June 2007.
- [21] Changjian Zhan, V.K. Ramachandaramurthy, A. Arulampalam, M. Barnes, G. Strbac N. Jekin "Dynamic Voltage Restorer Based On Voltage Space Vector Pwm Control", IEEE 2001.
- [22] M. R. Banaei, S. H. Hosseini, And M. Daekalee Khajee, "Mitigation Of Voltage Sag Using Adaptive Neural Network With Dynamic Voltage Restorer" IEEE 2006.
- [23] D. Mahinda Vilathgamuwa, H. M. Wijekoon, And S.S. Choi, "Interline Dynamic Voltage Restorer: A Novel And Economical Approach For Multiline Power Quality Compensation" IEEE 2004.
- [24] Ali O Al-Mathunani, Azah Mohamed, And Mohd Alauddin Mohd Ali, "Photovoltaic Based Dynamic Voltage Restorer For Voltage Sag Mitigation" IEEE 2007.
- [25] B. H. Li, S. S. Choi, And D. M. Vilathgamuwa, "Design Consideration On The Line -Side Filter Used In The Dynamic Voltage Restorer" IEEE 2001.
- [26] Dipesh. M .Patel, Dattesh Y. Joshi, Sameer H. Patel, hiren S. Parmar "Operation of Dstatcom For Voltage Control In Distribution Networks With A New Control Strategy" National Conference On Recent Trends In Engineering & Technology, 13th & 14th May-2011
- [27] S. Tara Kalyani, G. Tulasiram Das "Simulation Of Real And Reactive Power Flow Control With Upfc Connected To A Transmission Line" Journal Of Theoretical And Applied Information Technology, © 2008 Jatit.
- [28] N.G. Hingorani And L. Gyugyi, "Understanding Facts - Concepts And Technology Of Flexible Ac Transmission Systems", New York, IEEE Press

2000

- [29] K.R.Padiyar “Facts Controllers In Power Transmission And Distribution”, New Age International Publishers, 2007.
- [30] P. Kundur, “Power System Stability And Control”, Mcgraw-Hill 1999