

# Aquaponics Pilot System: Case Study

Stefan Buchdid Cardoso<sup>1</sup>, Pedro Paulo Teles Bianchini<sup>2</sup>, João Alberto Farinelli Pantaleão<sup>3</sup>, Vitor Miranda Pereira<sup>4</sup>, Mônica Hitomi Okura<sup>5</sup>

<sup>1</sup>Department of Engineer, Federal University of Triângulo Mineiro, Brazil

Email: stefanbuchdid@yahoo.com.br

<sup>2</sup>Department of Engineer, Federal University of Triângulo Mineiro, Brazil

Email: pedro-bianchini@hotmail.com

<sup>3</sup>Department of Engineer, Federal University of Triângulo Mineiro, Brazil

Email: pantaleaojaf@gmail.com

<sup>4</sup>Department of Engineer, Federal University of Triângulo Mineiro, Brazil

Email: vitor\_mpereira@hotmail.com

<sup>5</sup>Department of Engineer, Federal University of Triângulo Mineiro, Brazil

Email: monica.okura@gmail.com

**Abstract**— The aquaponics term derives from the words aquaculture and hydroponics, which by definition, has the meaning of aquatics organisms culture and plant breeding techniques without soil, respectively. This activity has how the main feature the sustainability, once the modality looks for the production with low water consumption and high exploitation of waste generated. The present study had as objective to describe the construction of the aquaponics pilot system. This way, based on the literature and acquired experience during the work, a step-by-step method was established for the assembly of the system. To verify the process efficiency, were analyzed the presence of total and thermotolerants coliforms, counting of facultative mesophiles and quantification of micro and macronutrients in leaves and roots of *Xanthosoma sagittifolium*. There was no presence of total and thermotolerants coliforms in leaves and roots of *X. sagittifolium*. In the count of facultative mesophiles the roots presented  $6 \times 10^4$  CFU/g and the leaves  $1.7 \times 10^2$  CFU/g. In the foliar analysis, 1430mg/kg of Fe was observed in the roots. It was concluded that the pilot project was successfully built and testing can be continued with new plants.

**Keywords**— Aquaculture, Hydroponics, Low water consumption, Sustainability, *Xanthosoma sagittifolium*.

## I. INTRODUCTION

The growing world population associated with the increased demand for water exerts enormous pressure on the food production sectors, where the maximization and optimization of spaces and natural resources needs the development of integrated production systems (ONU, 2016). Therefore, the food production with minimal loss of water and nutrients is one necessity, where the aquaponics shows one possibility to that (CARVALHO et al., 2017). According to Carneiro et al. (2015) aquaponics is a new modality of food production with low consumption of water and high utilization of organic residue generated. This activity can be placed like a solution to the traditional methods of agriculture, which shows high environmental impact (HUNDLEY, 2013).

Aquaponics can stimulate the interested population in the development of the familiar agriculture in the urban perimeter, since it can be realized in small spaces like house gardens, apartments and terrace of buildings. This way the aquaponics study, looking for the technological development of the technique in good prices and within

the norms of sanitary control, allows including a larger number of people who practice this activity. Families can benefit from the food produced and can offer the surplus of their productions in markets near to their residence, dynamizing the economy of low-income regions (PINTO, 2015).

The reasons for reuse of water stems from its scarcity, pollution control and probable economic gains. The necessary water volume to fuel one aquaponic system is not big because the system recycle the water (CARVALHO et al, 2017). The benefits of this culture are multiple and involve subjects like health, nutrition, poverty, sanitation, valuing local culture and, specially, environmental education contributing greatly to the sustainable development of cities (BUSS et al, 2015).

The aquaponic success depends, basically, on water quality, quantity of food supplied, residence time of the water inside the system, the species cultivated, the storage density and biomass of organisms (CARVALHO et al., 2017). The present work proposed to develop an aquaponic system to be used as a research tool,

integrating the production of *Xanthosoma sagittifolium* (L. Schott) with *Astyanax bimaculatus* (Lütken, 1875).

## II. METHODOLOGY

### 2.1 Construction of the system

The present work was conducted based on a bibliographic review, being adapted to the needs of the project. The pilot system was built inside the campus Univerdecidade – unit 1 – Federal University of Triângulo Mineiro (UFMT), Uberaba, state of Minas Gerais, Brazil. It is intended to clarify that all steps were based on Brazilian Agricultural Research Corporation (Embrapa) literature review, followed during the project.

It is emphasized that this system is part of a research project, where the effects of the system in the *Xanthosoma sagittifolium* planted in expanded clay like substrate is being analyzed.

### 2.2 Schematic illustrations

The schematic illustrations were elaborated in the program Sketch up (2018 version).

### 2.3 Total and Thermotolerants coliforms and facultative mesophiles counting in leaves of *Xanthosoma sagittifolium*.

The presence of total and thermotolerants coliforms in leaves and roots of *X. sagittifolium* were analyzed. This vegetal species was selected because it was the first plant inserted in the system and exposed to water from the fish tank.

For the microbiological analysis of the plants, we used the technique Most Probably Number (MPN), in which each dilution of the samples was seeded in three series of three glass tubes with Durhan tube containing Lauryl Sulphate Tryptose Broth (LST). Once we found positive tubes, they were incubated in test tubes containing Durhan tubes in Brilliant Green Bile Broth and Escherichia coli Broth. The calculations of MPN were made based on the table of Hoshins.

To the count of facultative mesophiles we used the Pour Plate technique. The water was submitted to three serial dilutions and 1 mL of each dilution gone to sterile Petri plates with 20 mL of Plate Count Agar. The plates were incubated at 37°C for 48 h (SILVA et al., 2007).

### 2.4 Analysis of the concentration of macro and micronutrientes in *Xanthosoma sagittifolium*

For the definition of macro and micronutrient concentrations present in the leaves and roots of *X. sagittifolium*, to assess nutritional status, an adult plant was removed from the grow bed and sent to laboratorial analysis in one accredited laboratory, located in Uberaba – MG, Brazil. The laboratory uses the method proposed by ESALQ, 1997 C6.

## III. RESULTS AND DISCUSSION

### 3.1 Description of the pilot system assembly

Externally to the greenhouse, the intensive recirculation system was built. Composed by one container IBC (Intermediate Bulk Container) cut in 70 cm of height with capacity for 500 liters, which was the fish tank (Figure 1). The chosen species was *Astyanax bimaculatus*.

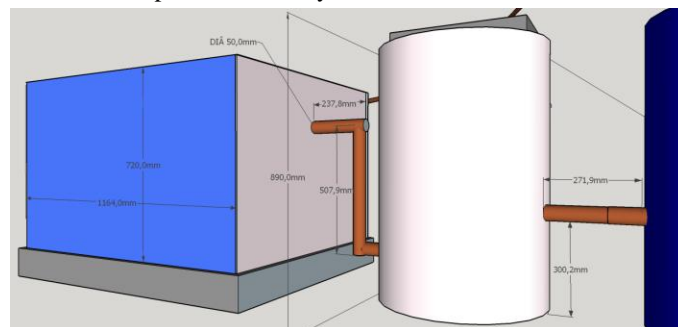

Fig. 1: Schematic illustration of the intensive recirculation system.

The choice of container was because it had a metallic structure on the outside and one pallet below. These structures are very important to the sustentation of the system. The tank was painted in frosted blue to reduce the light input, because the lightness helps the proliferation of algae in the tank. It could be injurious to the system because the algae consume the dissolved oxygen during the night, when they do not realize photosynthesis (Figure 2) (CETESB, 2019).



Fig. 2: Model of IBC container used in the aquaponics pilot system.

Two barrels with 200 L capacity were used. The first one with decanter function and the second as clean water tank (Figure 3).

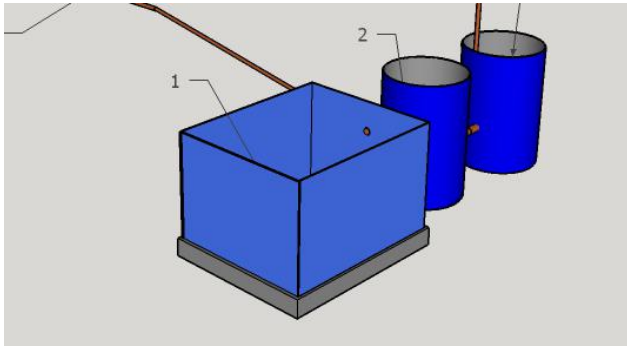

Fig. 3: Disposal of tank and barrels.

The first barrel, with decanter function, receives water from the fish tank through an entrance on the bottom. The barrel has a round shape and, because of this, it was installed in the entrance of water one 90° elbow. In this way, the water can enter tangentiating the wall of the recipient, creating a circular movement inside. This movement is responsible to the process of decantation where the solids are retained in the bottom (Figure 4).



Fig. 4: Inlet and exit of the barrel with decanter function.

The solid residue deposited on the bottom of the barrel can be used as fertilizer in conventional techniques of agriculture, because these solids are organic matter, which came from fish waste.

The second barrel has the function of storing clean water and receives the previously decanted water. From there, the water is pumped to the fish tank and to the grow bed. After that, the entire cycle of recirculation is completed (Figure 5).



Fig. 5: Intensive recirculation system.

The pump chosen was a Sarlobetter® SB2000 with flow rate of 1,950 Lh<sup>-1</sup> and maximum water column height of 2,1m. This model met all the system requirements, making possible all the water circulation by the distance and height needed.

The grow bed was built with the top of cutted IBC container. It has 30 cm of height and is located inside the greenhouse. For its support and leveling, we used concrete blocks, pipelines of 25 mm diameter, pipe fittings, expanded clay and stone gravel. The middle of the container was cut and one 25 mm flange was installed (Figure 6). In this flange one piece of PVC pipe with the same diameter and with 20 cm of height was installed. This pipe determines the height of water. The height chosen was less than 30 cm because the grow bed must have a dry zone, for preventing algae growth (Figure 7).

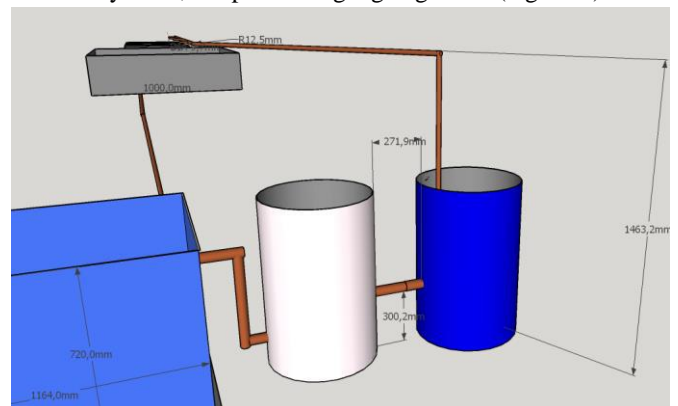

Fig. 6: Distances between decanter, clean water barrel and rhizospheric filter (grow bed).



Fig. 7: Rhizospheric filter with water leveler.

The expanded clay and stone gravel were responsible for the plants sustentation and by the colonization of bacteria. These two materials were placed in the same quantity (in kg), in a proportion of 1:1. The stone gravel is denser than the expanded clay (Figure 8).



Fig. 8: Filter with stone gravel and expanded clay.

According to Embrapa (2018) with the passage of the time the bacteria of the genus Nitrobacter and Nitrosomonas inhabit the filter and they are responsible to transforming the ammonia contained in the fish excrete into nitrite and nitrate, where nitrate is the assimilable form by the plants.

As well as the grow bed, which has the main function of rhizospheric filtration, three more similar structures with smaller size and volume were built. These structures had the same functioning of the first, but with different objectives. While the first is part of the filtration process, X. sagittifolium was planted. In the other three, Lactuca sativa L. (Lettuce) was planted (Figure 9).

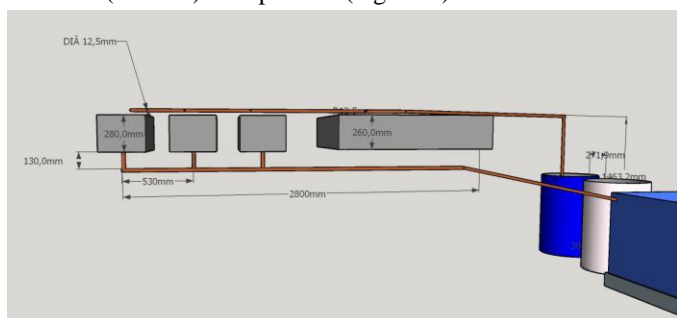

Fig. 9: Measures of the Lettuce grow beds.

Posteriorly, a siphon (bell siphon) with PVC pipe of 75 mm diameter was built. The pipe has 30 cm of height and was placed in the top of water leveler. The pipe was capped and perforated. After that, a piece of 20 cm of hose and with the same diameter of the perforation was installed. The siphon has the function of removing all the water from the grow bed from time to time.

This siphon empties the grow bed only when it is full of water. The liquid takes the place of the air in the hose of siphon, creating a vacuum, removing all the air of the hose, starting the process of emptying. When the entire volume of water in the grow bed is drained, the air enters by the hose and the flush stops, initiating the process of refill.

This process is necessary because the roots of the plants needs to have contact with the air, not only water, avoiding the rotting of the roots. This oscilation brings benefits because the inlet of the atmospheric air in the roots of the plants keeps them healthy (HUNDLEY, 2013).

### 3.2 Total and Thermotolerants Coliforms and facultative mesophiles in Xanthosoma sagittifolium.

In the root and leaves of X. sagittifolium it was not observed the presence of total and thermotolerants coliforms. In the counting of facultative mesophiles there was 6x10<sup>4</sup> CFU/ml in the roots and 1,7x10<sup>2</sup> CFU/ml in the leaves (Table 1).

Table 1. Results of analysis

|                                    | Roots             | Leaves              |
|------------------------------------|-------------------|---------------------|
| Total Coliforms (MPN/ml)           | 0                 | 0                   |
| Thermotolerants Coliforms (MPN/ml) | 0                 | 0                   |
| Standard Plate Count (CFU/ml)      | 6x10 <sup>4</sup> | 1,7x10 <sup>2</sup> |

### 3.3 Macro and Micronutrients Concentration in Xanthosoma sagittifolium.

According to Pinto et al. (1999), the leaves show high levels of minerals and can be classified as an important source of iron (Fe), potassium (K), calcium (Ca) and manganese (Mn). In addition to low calorie, they show high levels of proteins, fibers, vitamin C (PINTO et al., 2001). In Brazil, X. sagittifolium is very appreciated in states of Minas Gerais, Bahia and Rio de Janeiro, being utilized in typical dishes (MANGAN et al., 2008).

Through laboratory analysis we can note that the essential nutrients to the plant development are present (Table 2). The visual aspect is of a healthy leaf (Figure 9).

Table 2. Foliar analysis of roots and leaves of *Xanthosoma sagittifolium*.

| Macronutrients | Unit  | Leaf and stalk | Roots |
|----------------|-------|----------------|-------|
| Nitrogen (N)   | g/kg  | 25.59          | 24.64 |
| Phosphorus (P) | g/kg  | 3.38           | 3.73  |
| Potassium (K)  | g/kg  | 33.53          | 31.47 |
| Calcium (Ca)   | g/kg  | 17.3           | 10.35 |
| Magnesium(Mg)  | g/kg  | 3.34           | 5.6   |
| Sulfur (S)     | g/kg  | 0.69           | 1.67  |
| Micronutrients | Unit  | Leaf and stalk | Roots |
| Boron (B)      | mg/kg | 17.2           | 10.6  |
| Copper (Cu)    | mg/kg | 6.2            | 25.8  |
| Iron (Fe)      | mg/kg | 128.8          | 1430  |
| Manganese(Mn)  | mg/kg | 16.4           | 46.8  |
| Zinc (Zn)      | mg/kg | 26.9           | 98.5  |

It was also possible to note, with the exception of boron (B), a higher quantity of micronutrients in *X. sagittifolium* roots. Iron (Fe), in particular, accumulated in significantly higher amounts.



Fig. 10: Size and aspect of *Xanthosoma sagittifolium* leaves. (Scale = 30cm)

#### IV. CONCLUSION

It was possible to build a pilot aquaponic system using materials, mostly, reused. The system was used successfully for the development of research projects for students of the Environmental Engineering courses at UFTM.

As there was no presence of total and thermotolerant coliforms in the leaves and roots of *Xanthosoma sagittifolium*, the aquaponic vegetable can be consumed as human food. Besides the leaves are washed and cooked before consumption.

About the concentrations of micro and macronutrients in

*X. sagittifolium* leaves, it was concluded that there is a higher concentration of micronutrients, with the exception of Boron (B), in the roots of the plants. The Iron (Fe) accumulates in an expressively way in the roots.

#### REFERENCES

- [1] BUSS, A.B. A. B. ; Meurer, V.N. ; AQUINI, E. N. ; Alberton, J. V. ; Bardini, D.S. ; Freccia, A. . Desenvolvimento de Aquaponia como alternativa de produção de alimentos saudáveis em perímetro urbano. In: VI Seminário de Ensino Pesquisa e Extensão do Centro Universitário Barriga Verde - UNIBAVE, 2015, Orleans - SC. Anais da VI SENPEX do Centro Universitário Barriga Verde, 2015. p. 1127-1132.
- [2] CARNEIRO, P.C.F.; MARIA, A.N.; NUNES, M.U.C.; FUJIMOTO, R.Y. Aquaponia: produção sustentável de peixes e vegetais. In: Tavares-Dias, M. & Mariano, W.S. (Org.) Aquicultura no Brasil: novas perspectivas. São Paulo, Editora Pedro & João, 2015. Myers, D. G. (2007). Psychology (1st Canadian ed.). New York, NY: Worth.
- [3] CARVALHO, A.R.; BRUM, O.B.; CHIMÓIA, E.P.; FIGUEIRÓ, E.A.G. Avaliação da produtividade da aquaponia comparada com a hidroponia convencional. Rev. Vivência. v.13, n.24, p.79-91, 2017. Blue, L. (2008, March 12). Is our happiness preordained? [Online exclusive]. Time. Retrieved from <http://www.time.com/time/health>
- [4] CETESB. . Matéria Orgânica e Nutrientes. 2019. Disponível em: <<https://cetesb.sp.gov.br/mortandade-peixes/alteracoes-fisicas-e-quimicas/materia-organica-e-nutrientes/>>. Acesso em: 16 jun. 2019.
- [5] EMBRAPA. Pesca e Aquicultura. 2018. Disponível em: <<https://www.embrapa.br/tema-pesca-e-aquicultura/nota-tecnica>>. Acesso em: 28 maio 2018.
- [6] HUNDLEY, G. C. Aquaponia, uma experiência com tilápia (*Oreochromis niloticus*), manjeriço (*Ocimum basilicum*) e manjerona (*Origanum majorana*) em sistemas de recirculação de água e nutrientes. Monografia (Graduação em Agronomia) – Universidade de Brasília – UnB, Brasília, 2013.
- [7] MANGAN, F.X.; MENDONÇA, R.U.; NUNES, S.V.; FINGER, F.L.; BARROS, Z.J.; GALVÃO, H.; ALMEIDA, G.C.; SILVA RAN; ANDERSON, M.D. Production and marketing of vegetables for the ethnic markets in the United States. Horticultura Brasileira, vol. 26, p. 06-14, 2008.
- [8] ONU. FAO: Como alimentar a crescente população global? Disponível em: <<https://nacoesunidas.org/fao-como-alimentar-a-crescente-populacao-global/>>. Acesso em: 29 jun. 2018.
- [9] PINTO, H. S. Você sabe o que é Aquaponia? Entenda como essa atividade pode auxiliar as estratégias de segurança alimentar e nutricional atuais. Brasília: Núcleo de Estudos e Pesquisas/CONLEG/Senado, agosto/2015 (Boletim Legislativo nº 32, de 2015). Disponível em: <[www.senado.leg.br/estudos](http://www.senado.leg.br/estudos)>. Acesso em 28 de maio de 2018.

- [10] PINTO, N.A.V. D., CARVALHO, V. D. , BOAS, B. M. V.; Caracterização Mineral das Folhas de Taioba, Ciênc. e Agrotec. 23, n.1, 57-61, 1999.
- [11] PINTO, N. A. V.D., FERNANDES, S. M., THÉ, P. M. P., CARVALHO, V.D.; Variabilidade da Composição Centesimal, Vitamina C, Ferro e Cálcio de Partes da Folha de Taioba, Rev. Bras. de Agrociência, 7, n. 3, 205-208, 2001.
- [12] SILVA, N.; JUNQUEIRA, V. C. A.; SILVEIRA, N. F. A.; TANIWAKI, M. H.; SANTOS, R. F. S.; GOMES, R. A. R. Manual de métodos de análise microbiológica de alimentos. 3 ed. São Paulo: Livraria Varela, 2007. 552p.